

CYLINDERS WITH INTEGRATED GUIDE

SERIES QCTF - QCBF

Double-acting, magnetic, with double bearings and flanges
 Ø 20, 25, 32, 40 mm

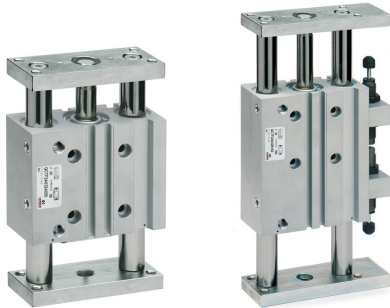

- Magnetic sensors can be mounted on both sides
- Series QCTF:
 - Bronze bushings version.
- Series QCBF:
 - Ball bearing guide version.
- Movement and guide in one unit

These cylinders have been designed to be used in applications where space is limited.

Regarding the bearings, the Slide Units are available in two versions, one with double sintered bronze bushes (Mod. QCTF) and the other with double linear ball bearings (Mod. QCBF).

The QCTF version would normally be selected when the side loads applied to the slide unit are high. Mod. QCBF is suitable for fast cycles (less side load) and higher precision.

The end cushioning is available in three different variants:

- Fixed mechanical cushion (standard);
- With two shock absorbers located on the body;
- With one shock absorber located central on the rear flange.

GENERAL DATA

Type of construction	Guided with double bearings and double flanges QCTF = sintered bronze bushes QCBF = linear ball bearings
Operation	Double-acting
Materials	Body = anodized AL flanges = zinc-plated steel piston rod = rolled stainless steel AISI QCTF columns = rolled stainless steel 420B QCBF columns = hardened steel C50 seals = PU
Mounting	Threaded and non threaded holes in the body
Strokes min. max	(see table)
Operating temperature	0°C ÷ 80°C (with dry air -20°C)
Speed	50 ÷ 500 mm/s
Stroke end cushioning Type A	Extended stroke - fixed mechanical cushioning retracted stroke - fixed mechanical cushioning we recommend preventing the piston from striking against the end covers
Stroke end cushioning Type B	Extended stroke - shock absorber retracted stroke - shock absorber
Stroke end cushioning Type C	Extended stroke - shock absorber retracted stroke - fixed mechanical cushioning we recommend preventing the piston from striking against the end covers
Operating pressure	1 ÷ 10 bar
Fluid	Clean air, non lubricated. If lubricated air is used, it is recommended to use oil ISOVG32. Once applied the lubrication should never be interrupted.

Standard strokes

■ = Type A and C Out of standard intermediate strokes available on request (strokes multiple of 5 mm)
 ✘ = Type B

∅	20	25	30	40	50	75	100	125	150	175	200
20	■		■	■	■	■ ✘	■ ✘	■ ✘	■ ✘	■ ✘	■ ✘
25	■		■	■	■	■ ✘	■ ✘	■ ✘	■ ✘	■ ✘	■ ✘
32		■			■	■	■ ✘	■ ✘	■ ✘	■ ✘	■ ✘
40		■			■	■	■ ✘	■ ✘	■ ✘	■ ✘	■ ✘

Coding Examples

QC	T	F	2	A	020	A	050
QC	SERIES						
T	TYPE OF BEARING T = sintered bronze bushes B = linear ball bearings						
F	VERSION F = double flange						
2	OPERATION 2 = double-acting						PNEUMATIC SYMBOL CD14
A	MATERIALS A = anodized aluminium body - rolled stainless steel piston rod AISI 303 rolled stainless steel AISI 420B columns for QCTF - hardened steel C50 columns for QCBF						
020	BORE 020 = 20 mm - 025 = 25 mm - 032 = 32 mm - 040 = 40 mm - 050 = 50 mm						
A	CUSHION A = fixed mechanical cushion (standard) B = two shock absorbers located on the body C = one shock absorber located on the rear flange						
050	STROKE (see the table)						
	CERTIFICATIONS = Standard EX = ATEX						

Pneumatic symbols

The pneumatic symbols which have been indicated in the CODING EXAMPLE are shown below.

CD28

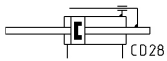
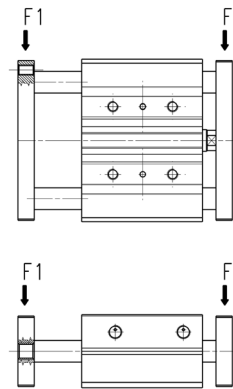

Table of permissible loads (F1)

For sintered bronze bushes QCTF version
 For linear ball bearings QCBF version

F1 (N) 1N = 0.102 kgf



∅		20	25	30	40	50	75	100	125	150	175	200
20	QCTF	136	-	124	124	123	122	122	121	121	120	120
	QCBF	146	-	142	140	139	137	136	134	94	70	53
25	QCTF	181	-	167	165	164	163	162	161	160	159	158
	QCBF	171	-	167	165	163	161	160	160	159	142	109
32	QCTF	-	174	-	-	166	162	160	158	156	155	153
	QCBF	-	220	-	-	214	211	211	210	210	209	209
40	QCTF	-	189	-	-	175	168	164	161	159	157	155
	QCBF	-	228	-	-	219	214	214	212	212	211	210

Table of permissible moments (M1)

For sintered bronze bushes QCTF version
 For linear ball bearings QCBF version

M1 (N*m) 1N*m = 0,102 kgf *m

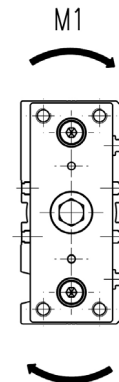

∅	Mod.	20	25	30	40	50	75	100	125	150	175	200
20	QCTF	3,6	-	3,3	3,3	3,3	3,2	3,2	3,2	3,2	3,2	3,2
	QCBF	3,9	-	3,7	3,7	3,7	3,6	3,6	3,6	2,5	1,89	1,4
25	QCTF	5,7	-	5,2	5,2	5,2	5,2	5,1	5,1	5,1	5	5
	QCBF	5,4	-	5,2	5,2	5,2	5,1	5,1	5,1	5	4,5	3,4
32	QCTF	-	6,7	-	-	6,4	6,3	6,2	6,1	6	6	5,9
	QCBF	-	8,5	-	-	8,3	8,2	8,2	8,1	8,1	8,1	8,1
40	QCTF	-	8,1	-	-	7,5	7,2	7	6,9	6,8	6,7	6,6
	QCBF	-	9,8	-	-	9,4	9,2	9,2	9,1	9,1	9	9

Cylinders QCTF and QCBF type "A"

PNEUMATIC ACTUATION

1

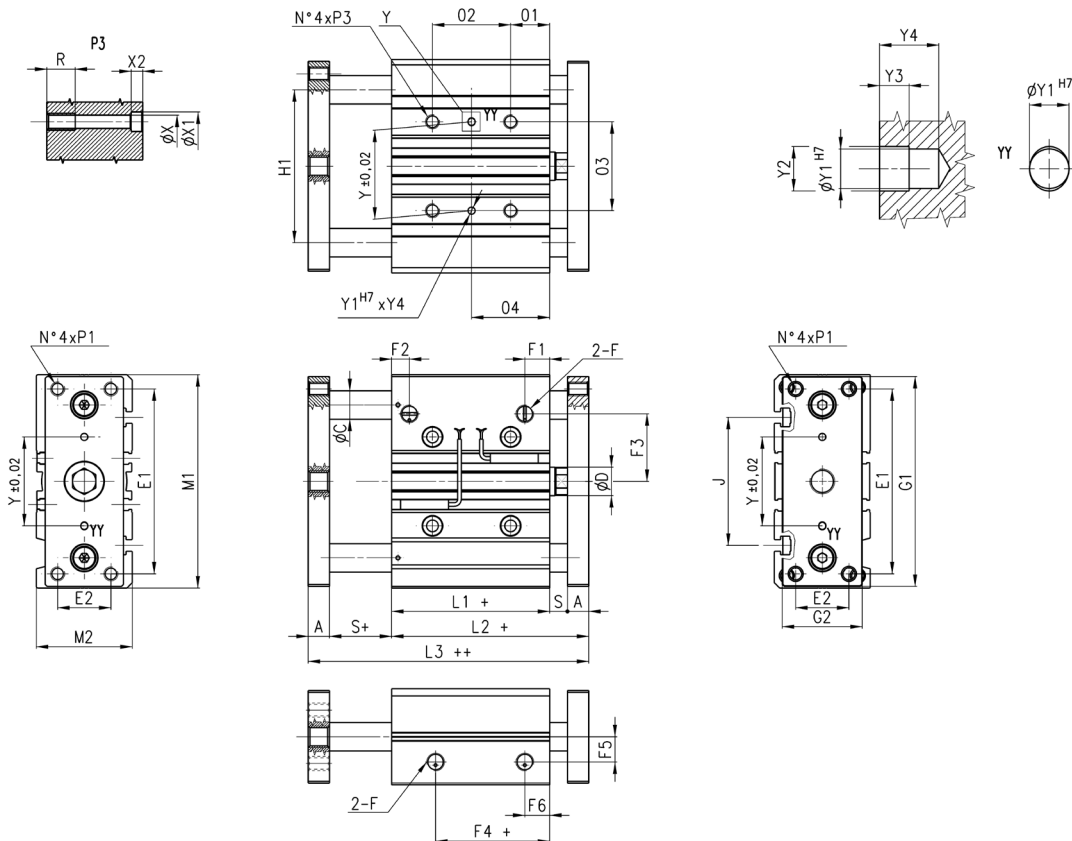

In case of use of lateral ports, unscrew the related threaded caps, screw them in the front ports and tighten them up to the cylinder surface (not tighter) having care to use a proper sealer.

Ø	A	D	E1	E2	F	F1	F2	F3	F4	F5	F6	G1	G2	H1	L1	L2	L3	M1	M2	O1	O3	R	S	Y
20	10	10	70	18	1/8	10,5	10,5	25	12,5	11,5	10,5	81	30	54	37	53	69	83	36	17	28	12	6	28
25	10	12	78	26	1/8	11,5	8	28,5	12,5	13,5	11,5	91	40	64	37,5	53,5	69,5	93	42	17	34	12	6	34
32	12	16	96	30	1/8	12,5	9,5	34	7	15	12,5	110	45	78	37,5	59,5	81,5	112	48	21	42	16	10	42
40	12	16	104	30	1/8	13	12	38	13	18	13	118	45	86	44	66	88	120	54	22	50	16	10	50

Ø	P1	P3	Y1	Y2	Y3	Y4	X	X1	X2	J	K
20	M5x0,8	M6x1	3	3,5	3	6	5,5	9	5	44	M5
25	M6x1	M6x1	4	4,5	3	6	5,5	9	5	50	M5
32	M8x1,25	M8x1,25	4	4,5	3	6	6,5	11	6,5	63	M6
40	M8x1,25	M8x1,25	4	4,5	3	6	6,5	11	6,5	72	M6
	02 stroke 20-30	02 stroke 40-100	02 stroke 125-200		04 stroke 20-30	04 stroke 40-100				ØC QCBF	ØC QCTF
20	24	44	120		29	39	77		10	12	
25	24	44	120		29	39	77		12	16	
32	24	48	124		33	45	83		16	20	
40	24	48	124		34	46	84		16	20	

Cylinders QCTF and QCBF type "C"

PNEUMATIC ACTUATION

1

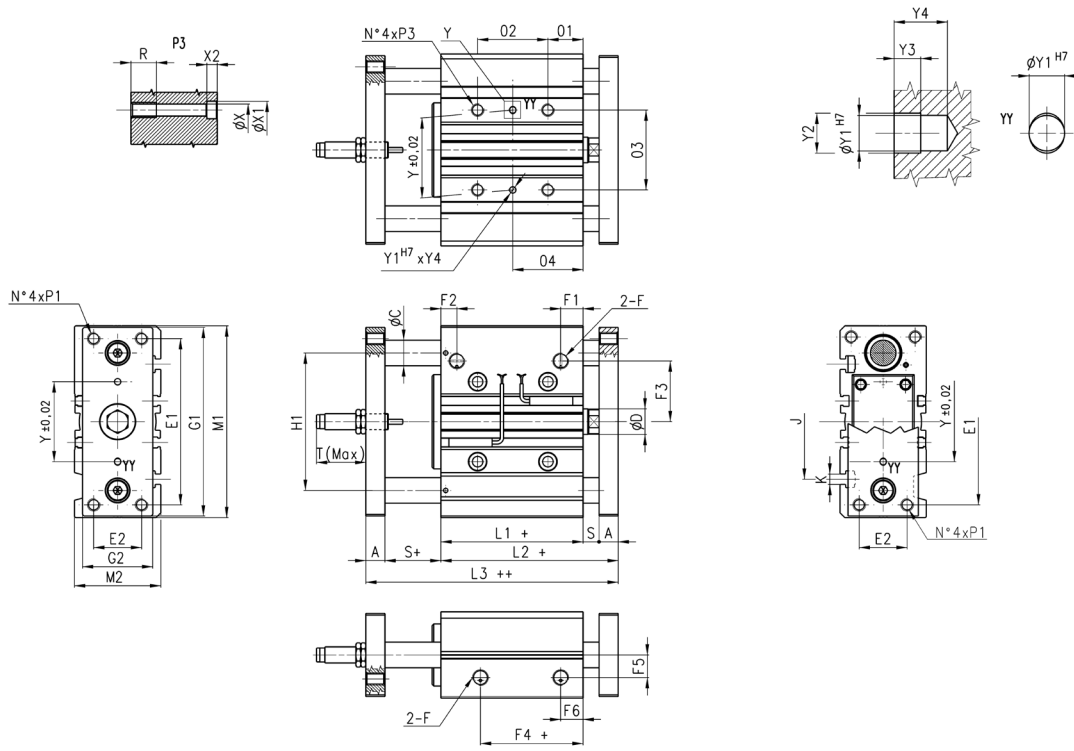

In case of use of lateral ports, unscrew the related threaded caps, screw them in the front ports and tighten them up to the cylinder surface (not tighter) having care to use a proper sealer.

Ø	P1	P3	T	Y	Y1	Y2	Y3	Y4	X	X1	X2	J	K	Shock absorber	Δ stroke (mm)	adjustment range cyl. stroke mm
20	M5x0,8	M6x1	37	28	3	3,5	3	6	5,5	9	5	44	M5	SA-1007 W	0 ÷ 25	-15 ÷ -25
25	M6x1	M6x1	37	34	4	4,5	3	6	5,5	9	5	50	M5	SA-1007 W	0 ÷ 25	-15 ÷ -25
32	M8x1,25	M8x1,25	55	42	4	4,5	3	6	6,5	11	6,5	63	M6	SA-1412 W	0 ÷ 35	-18 ÷ -35
40	M8x1,25	M8x1,25	55	50	4	4,5	3	6	6,5	11	6,5	72	M6	SA-1412 W	0 ÷ 35	-18 ÷ -35
	Ø2 stroke 20-30	Ø2 stroke 40-100	Ø2 stroke 125-200	Ø4 stroke 20-30	Ø4 stroke 40-100	Ø4 stroke 125-200		QCBF ØC	QCTF ØC							
20	24	44	120	29	39	77		10	12							
25	24	44	120	29	39	77		12	16							
32	24	48	124	33	45	83		16	20							
40	24	48	124	34	46	84		16	20							

Ø	A	D	E1	E2	F	F1	F2	F3	F4	F5	F6	G1	G2	H1	L1	L2	L3	M1	M2	O1	O3	R	S
20	10	10	70	18	1/8	10,5	10,5	25	12,5	11,5	10,5	81	30	54	37	53	69	83	36	17	28	12	6
25	10	12	78	26	1/8	11,5	8	28,5	12,5	13,5	11,5	91	40	64	37,5	53,5	69,5	93	42	17	34	12	6
32	12	16	96	30	1/8	12,5	9,5	34	7	15	12,5	110	45	78	37,5	59,5	81,5	112	48	21	42	16	10
40	12	16	104	30	1/8	13	12	38	13	18	13	118	45	86	44	66	88	120	54	22	50	16	10

Magnetic proximity switches with 2- or 3-wire cable for T-slot

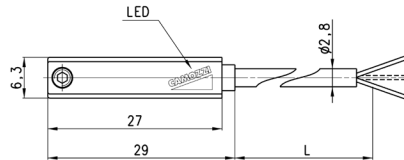
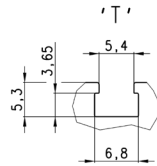

Mod.	Operation	Connections	Voltage	Output	Max. current	Max Load	Protection	L = length cable
CST-220	Reed	2 wires	10 ÷ 110 V AC/DC-230 V AC	-	250 mA	10 VA / 8 W	None	2 m
CST-220-5	Reed	2 wires	10 ÷ 110 V AC/DC-230 V AC	-	250 mA	10 VA / 8 W	None	5 m
CST-220-12	Reed	2 wires	10 ÷ 110 V AC/DC-230 V AC	-	250 mA	10 VA / 8 W	None	12 m
CST-220EX	Reed	2 wires	10 ÷ 110 V AC/DC-230 V AC	-	250 mA	10 VA / 8 W	None	2 m
CST-220-5EX	Reed	2 wires	10 ÷ 110 V AC/DC-230 V AC	-	250 mA	10 VA / 8 W	None	5 m
CST-220-12EX	Reed	2 wires	10 ÷ 110 V AC/DC-230 V AC	-	250 mA	10 VA / 8 W	None	12 m
CST-232	Reed	3 wires	5 ÷ 30 V AC/DC	PNP	250 mA	10 VA / 8 W	Against polarity reversing	2 m
CST-232-5	Reed	3 wires	5 ÷ 30 V AC/DC	PNP	250 mA	10 VA / 8 W	Against polarity reversing	5 m
CST-232EX	Reed	3 wires	5 ÷ 30 V AC/DC	PNP	250 mA	10 VA / 8 W	Against polarity reversing	2 m
CST-232-5EX	Reed	3 wires	5 ÷ 30 V AC/DC	PNP	250 mA	10 VA / 8 W	Against polarity reversing and overvoltage	5 m
CST-332	Magneto-resistive	3 wires	10 ÷ 27 V DC	PNP	100 mA	6 W	Against polarity reversing and overvoltage	2 m
CST-332-5	Magneto-resistive	3 wires	10 ÷ 27 V DC	PNP	100 mA	6 W	Against polarity reversing and overvoltage	5 m
CST-332EX	Magneto-resistive	3 wires	10 ÷ 27 V DC	PNP	100 mA	6 W	Against polarity reversing and overvoltage	2 m
CST-332-5EX	Magneto-resistive	3 wires	10 ÷ 27 V DC	PNP	100 mA	6 W	Against polarity reversing and overvoltage	5 m
CST-432	Reed	3 wires	5 ÷ 30 V AC/DC	PNP-NC	250 mA	10 VA / 8 W	Against polarity reversing	2 m
CST-432-5	Reed	3 wires	5 ÷ 30 V AC/DC	PNP-NC	250 mA	10 VA / 8 W	Against polarity reversing	5 m
CST-432EX	Reed	3 wires	5 ÷ 30 V AC/DC	PNP-NC	250 mA	10 VA / 8 W	Against polarity reversing	2 m
CST-432-5EX	Reed	3 wires	5 ÷ 30 V AC/DC	PNP-NC	250 mA	10 VA / 8 W	Against polarity reversing	5 m
CST-532	Hall effect	3 wires	10 ÷ 27 V DC	PNP	100 mA	6 W	Against polarity reversing and overvoltage	2 m
CST-532-5	Hall effect	3 wires	10 ÷ 27 V DC	PNP	100 mA	6 W	Against polarity reversing and overvoltage	5 m
CST-532EX	Hall effect	3 wires	10 ÷ 27 V DC	PNP	100 mA	6 W	Against polarity reversing and overvoltage	2 m
CST-532-5EX	Hall effect	3 wires	10 ÷ 27 V DC	PNP	100 mA	6 W	Against polarity reversing and overvoltage	5 m

Note for 2-wire switches Mod. CST-220, CST-220-5:
in case of polarity reversing the sensor will still be operating, but the LED diode won't turn on.

Magnetic proximity switches with M8 3-pin connector for T-slot

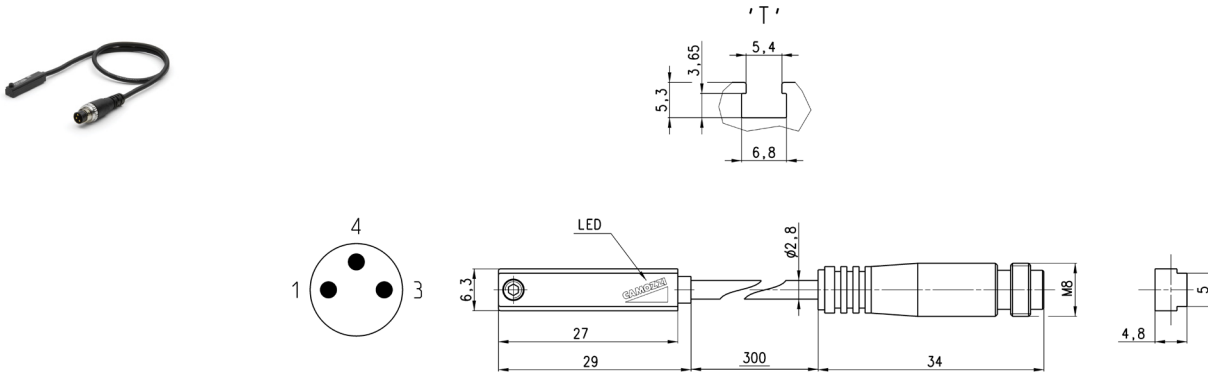

Cable length: 0,3 m

Mod.	Operation	Connection	Voltage	Output	Max. current	Max Load	Protection
CST-250N	Reed	2 wires M8 male 3 pin	10 ÷ 110 V AC/DC	-	250 mA	10 VA / 8 W	None
CST-250NEX	Reed	2 wires M8 male 3 pin	10 ÷ 110 V AC/DC	-	250 mA	10 VA / 8 W	None
CST-262	Reed	3 wires M8 male 3 pin	5 ÷ 30 V AC/DC	PNP	250 mA	10 VA / 8 W	Against polarity reversing
CST-262EX	Reed	3 wires M8 male 3 pin	5 ÷ 30 V AC/DC	PNP	250 mA	10 VA / 8 W	Against polarity reversing
CST-362	Magneto-resistive	3 wires M8 male 3 pin	10 ÷ 27 V DC	PNP	100 mA	6 W	Against polarity reversing and overvoltage
CST-362EX	Magneto-resistive	3 wires M8 male 3 pin	10 ÷ 27 V DC	PNP	100 mA	6 W	Against polarity reversing and overvoltage
CST-562	Hall effect	3 wires M8 male 3 pin	10 ÷ 27 V DC	PNP	100 mA	6 W	Against polarity reversing and overvoltage
CST-562EX	Hall effect	3 wires M8 male 3 pin	10 ÷ 27 V DC	PNP	100 mA	6 W	Against polarity reversing and overvoltage

Note for 2-wire switch Mod. CST-250N:
 in case of polarity reversing the sensor will still be operating, but the LED diode won't turn on

Magnetic proximity switches with M8 3-pin connector for H-slot

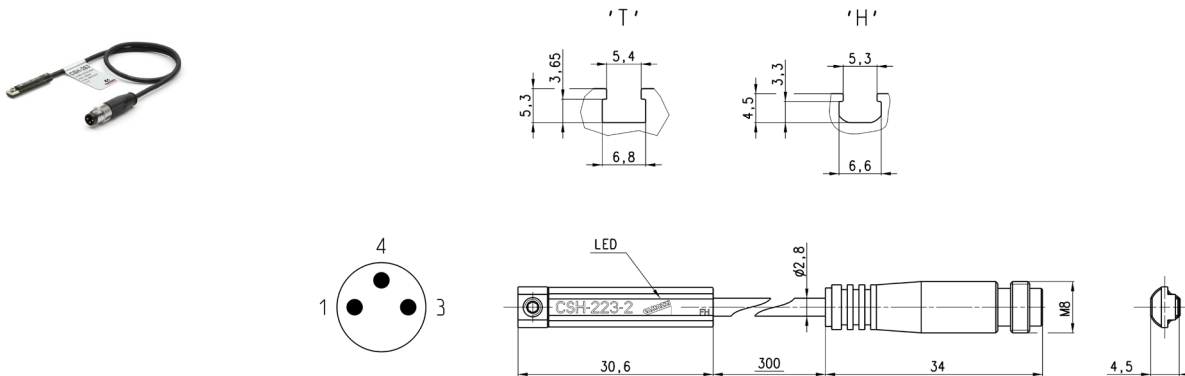

Cable length: 0,3 m

Mod.	Operation	Connection	Voltage	Output	Max. current	Max Load	Protection
CSH-253	Reed NO	2 wires M8 male 3 pin	10 ÷ 30 V AC/DC	-	250 mA	10 VA / 8 W	Against polarity reversing
CSH-253EX	Reed NO	2 wires M8 male 3 pin	10 ÷ 30 V AC/DC	-	250 mA	10 VA / 8 W	Against polarity reversing
CSH-263	Reed NO	3 wires M8 male 3 pin	10 ÷ 30 V AC/DC	PNP	250 mA	10 VA / 8 W	Against polarity reversing
CSH-263EX	Reed NO	3 wires M8 male 3 pin	10 ÷ 30 V AC/DC	PNP	250 mA	10 VA / 8 W	Against polarity reversing
CSH-364	Magneto-resistive	3 wires M8 male 3 pin	10 ÷ 27 V DC	PNP	250 mA	6 W	Against polarity reversing and overvoltage
CSH-364EX	Magneto-resistive	3 wires M8 male 3 pin	10 ÷ 27 V DC	PNP	250 mA	6 W	Against polarity reversing and overvoltage
CSH-463	Reed NC	3 wires M8 male 3 pin	10 ÷ 30 V AC/DC	PNP	250 mA	10 VA / 8 W	Against polarity reversing
CSH-463EX	Reed NC	3 wires M8 male 3 pin	10 ÷ 30 V AC/DC	PNP	250 mA	10 VA / 8 W	Against polarity reversing

Note for 2-wire switch Mod. CSH-253:
 in case of polarity reversing the sensor will still be operating, but LED diode won't turn on.

Magnetic proximity switches with 2 or 3 wire cable for H-slot

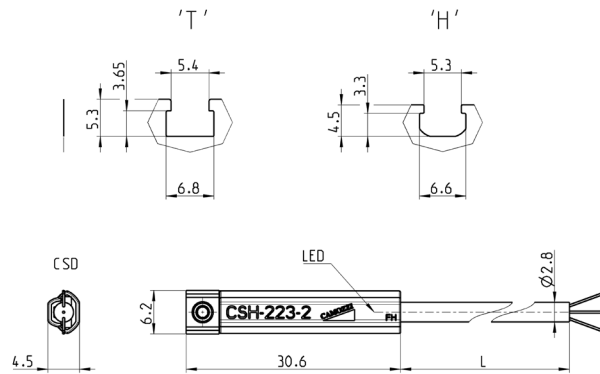

Mod.	Operation	Connection	Voltage	Output	Max. current	Max Load	Protection	L = cable length
CSH-223-2	Reed	2 wires	10 + 30 V AC/DC	-	250 mA	10 VA / 8 W	Against polarity reversing	2 m
CSH-223-5	Reed	2 wires	10 + 30 V AC/DC	-	250 mA	10 VA / 8 W	Against polarity reversing	5 m
CSH-223-10	Reed	2 wires	10 + 30 V AC/DC	-	250 mA	10 VA / 8 W	Against polarity reversing and overvoltage	10 m
CSH-223-2EX	Reed	2 wires	10 + 30 V AC/DC	-	250 mA	10 VA / 8 W	Against polarity reversing and overvoltage	2 m
CSH-223-5EX	Reed	2 wires	10 + 30 V AC/DC	-	250 mA	10 VA / 8 W	Against polarity reversing	5 m
CSH-223-10EX	Reed	2 wires	10 + 30 V AC/DC	-	250 mA	10 VA / 8 W	Against polarity reversing	10 m
CSH-221-2	Reed	2 wires	30 + 230 V AC - 30 ÷ 110 V DC	-	250 mA	10 VA / 8 W	Against polarity reversing	2 m
CSH-221-5	Reed	2 wires	30 + 230 V AC - 30 ÷ 110 V DC	-	250 mA	10 VA / 8 W	Against polarity reversing	5 m
CSH-221-2EX	Reed	2 wires	30 + 230 V AC - 30 ÷ 110 V DC	-	250 mA	10 VA / 8 W	Against polarity reversing	2 m
CSH-221-5EX	Reed	2 wires	30 + 230 V AC - 30 ÷ 110 V DC	-	250 mA	10 VA / 8 W	Against polarity reversing	5 m
CSH-233-2	Reed	3 wires	10 + 30 V AC/DC	PNP	250 mA	10 VA / 8 W	Against polarity reversing	2 m
CSH-233-5	Reed	3 wires	10 + 30 V AC/DC	PNP	250 mA	10 VA / 8 W	Against polarity reversing	5 m
CSH-233-2EX	Reed	3 wires	10 + 30 V AC/DC	PNP	250 mA	10 VA / 8 W	Against polarity reversing	2 m
CSH-233-5EX	Reed	3 wires	10 + 30 V AC/DC	PNP	250 mA	10 VA / 8 W	Against polarity reversing	5 m
CSH-334-2	Magneto-resistive	3 wires	10 + 27 V DC	PNP	250 mA	6 W	Against polarity reversing and overvoltage	2 m
CSH-334-5	Magneto-resistive	3 wires	10 + 27 V DC	PNP	250 mA	6 W	Against polarity reversing and overvoltage	5 m
CSH-334-2EX	Magneto-resistive	3 wires	10 + 27 V DC	PNP	250 mA	6 W	Against polarity reversing and overvoltage	2 m
CSH-334-5EX	Magneto-resistive	3 wires	10 + 27 V DC	PNP	250 mA	6 W	Against polarity reversing and overvoltage	5 m
CSH-433-2	Reed NC	3 wires	10 + 30 V AC/DC	PNP	250 mA	10 VA / 8 W	Against polarity reversing and overvoltage	2 m
CSH-433-5	Reed	3 wires	10 + 30 V AC/DC	PNP-NC	250 mA	10 VA / 8 W	Against polarity reversing	5 m
CSH-433-2EX	Reed	3 wires	10 + 30 V AC/DC	PNP-NC	250 mA	10 VA / 8 W	Against polarity reversing	2 m
CSH-433-5EX	Reed	3 wires	10 + 30 V AC/DC-	PNP-NC	250 mA	10 VA / 8 W	Against polarity reversing	5 m

Note for 2-wire switches Mod. CSH-223-2, CSH-223-5, CSH-221-2, CSH-221-5:
 in case of polarity reversing the sensor will still be operating, but the LED diode won't turn on.