

# CYLINDERS WITH INTEGRATED GUIDE

## SERIES QC

Double-acting, magnetic piston, guided  
 ø 20, 25, 32, 40, 50, 63 mm

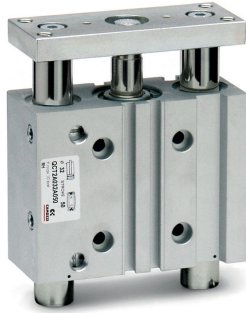

- Magnetic sensors can be mounted on both sides
- QCT: bronze bushings version
- QCB: ball bearing guide version
- Movement and guidance in one unit

These actuators, suitable for use in very limited space, are available in two versions.

QCT version: with sintered bronze bushes, suitable when the side loads applied to the cylinder are high.

QCB version: with linear ball bearings, suitable for high precision and fast cycling applications.

Both versions are equipped with fixed cushioning to prevent direct impact with the end covers. The design of the cylinder body allows the mounting of the cylinder using either top, bottom or side faces. Several "T" shaped grooves in two faces allow sensors to be fitted in a number of positions.

Out of standard strokes are available on demand only.

### General Data

<b>Type of construction</b>	Compact guided QCT = sintered bronze bushes QCB = linear ball bearings
<b>Operation</b>	Double-acting
<b>Materials</b>	Body = anodized AL Flange = zinc-plated steel Piston rod = rolled stainless steel AISI 303 QCT columns = rolled stainless steel 420B QCB columns = hardened steel C50 Seals = PU
<b>Mounting</b>	Threaded and non-threaded holes in the body
<b>Strokes min. max</b>	(see table)
<b>Operating temperature</b>	0°C ÷ 80°C (with dry air - 20°C)
<b>Speed</b>	50 ÷ 500 mm/s
<b>Operating pressure</b>	1 ÷ 10 bar
<b>Fluid</b>	Clean air, non lubricated. If lubricated air is used, it is recommended to use oil ISOVG32. Once applied the lubrication should never be interrupted.

## Standard strokes

■ = Double-acting

Out of standard intermediate strokes available on request (strokes multiple of 5 mm)

∅	20	25	30	40	50	75	100	125	150	175	200
20	■		■	■	■	■	■	■	■	■	■
25	■		■	■	■	■	■	■	■	■	■
32		■			■	■	■	■	■	■	■
40		■			■	■	■	■	■	■	■
50		■			■	■	■	■	■	■	■
63		■			■	■	■	■	■	■	■

## Coding Examples

QC	T	2	A	020	A	050
<b>QC</b>	SERIES					
<b>T</b>	VERSION T = sintered bronze bushes B = linear ball bearings					
<b>2</b>	OPERATION 2 = double-acting					<b>PNEUMATIC SYMBOLS</b> CD27
<b>A</b>	MATERIALS A = anodized aluminium body - rolled stainless steel AISI 303 piston rod rolled stainless steel AISI 420B columns for QCT - hardened steel C50 columns for QCB					
<b>020</b>	BORE 020 = 20 mm 025 = 25 mm 032 = 32 mm 040 = 40 mm 050 = 50 mm 063 = 63 mm					
<b>A</b>	TYPE OF DESIGN A = standard					
<b>050</b>	STROKE (see the table)					
	CERTIFICATIONS = Standard EX = ATEX					

## Pneumatic symbols

The pneumatic symbols which have been indicated in the CODING EXAMPLE are shown below.

CD27

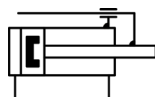

## Table of permissible loads (F)

For sintered bronze bushes QCT version.  
 For linear ball bearings QCB version.

F (N) 1N = 0.102 kgf

Ex.: QCT2A025A020 = F = 140N

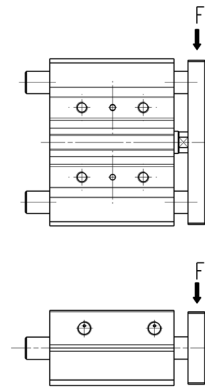

Ø	Mod.	20	25	30	40	50	75	100	125	150	175	200
20	QCT	100	-	93	81	73	114	93	98	85	75	67
25	QCT	140	-	120	115	103	165	135	150	131	116	104
32	QCT	-	253	-	-	214	225	208	225	198	176	159
40	QCT	-	251	-	-	197	215	206	224	196	175	157
50	QCT	-	317	-	-	273	267	299	257	225	200	179
63	QCT	-	316	-	-	273	267	299	257	225	200	179
20	QCB	110	-	100	125	121	90	86	69	58	49	43
25	QCB	142	-	85	154	148	106	82	97	81	70	61
32	QCB	-	222	-	-	91	167	129	145	122	104	90
40	QCB	-	221	-	-	93	167	128	145	121	104	90
50	QCB	-	203	-	-	152	161	193	156	130	110	95
63	QCB	-	201	-	-	151	158	195	157	130	110	94

## Table of permissible moments (M)

For sintered bronze bushes QCT version.  
 For linear ball bearings QCB version.

M (N\*m) 1N\*m = 0,102 kgf \*m

Ex.: QCT2A025A020 = M = 3,4 Nm

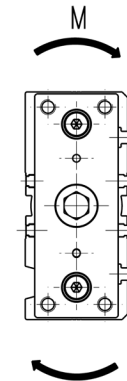

Ø	Mod.	20	25	30	40	50	75	100	125	150	175	200
20	QCT	1,7	-	1,5	1,2	1,0	2,9	2,8	2,6	2,3	2,0	1,8
25	QCT	3,4	-	2,9	3,6	3,3	4,2	4,3	3,8	3,2	2,7	2,3
32	QCT	-	6,7	-	-	6,5	7,2	7,0	6,6	5,6	4,8	4,1
40	QCT	-	8,7	-	-	7,3	9,2	8,8	9,6	8,4	7,5	6,7
50	QCT	-	15,4	-	-	12,9	12,6	13,4	12,1	11,3	10,7	8,8
63	QCT	-	15,1	-	-	14,3	16,6	17	14	11,3	9,7	9,1
20	QCB	3,0	-	2,7	3,4	3,3	2,4	2,3	1,9	1,6	1,3	1,2
25	QCB	3,5	-	2,7	4,9	4,7	3,4	2,6	3,1	2,6	2,2	2,0
32	QCB	-	6,3	-	-	3,6	6,5	5,1	5,7	4,8	4,1	3,5
40	QCB	-	8,5	-	-	4,0	7,2	5,5	6,2	5,2	4,5	3,9
50	QCB	-	11,1	-	-	8,3	8,8	10,6	8,6	7,1	6,0	5,2
63	QCB	-	8,3	-	-	7,2	9,8	12,1	9,7	8,1	6,8	5,8

Cylinders

PNEUMATIC ACTUATION

1

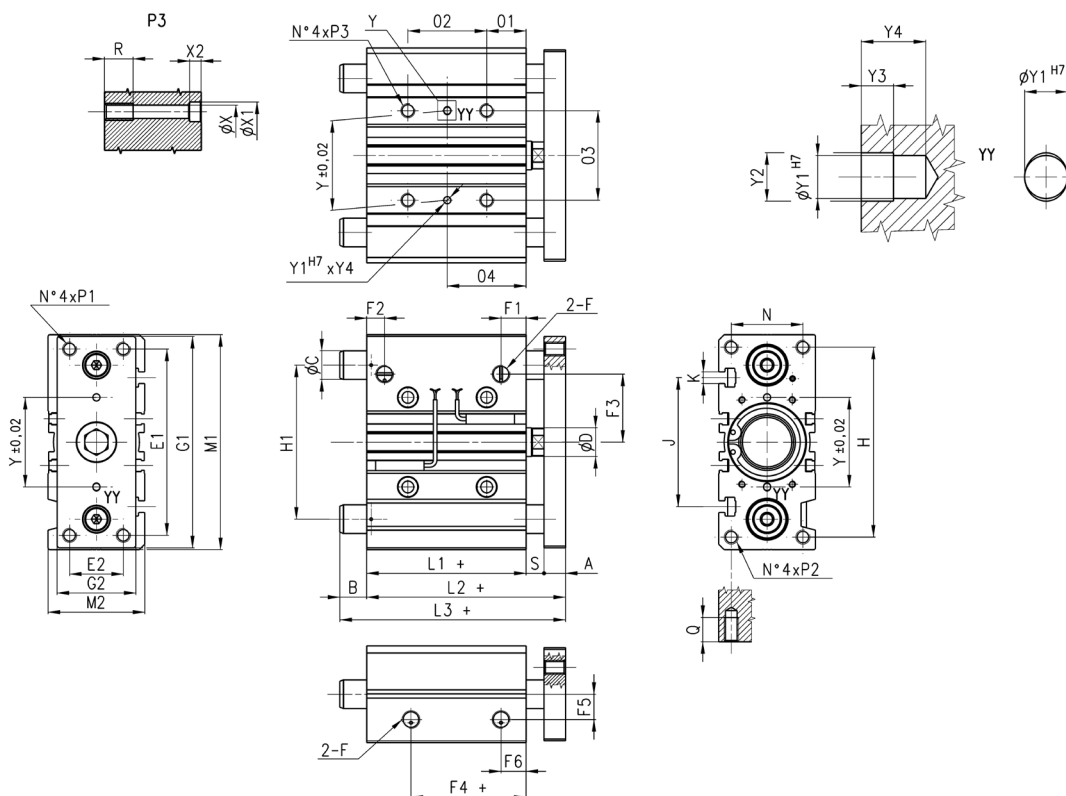

+ = add the stroke

In case of use of lateral ports, unscrew the related threaded caps, screw them in the front ports and tighten them up to the cylinder surface (not tighter) having care to use a proper sealer.

For out of standard intermediate strokes (ex. stroke 35), consider the immediately higher stroke dimensions (ex. stroke 40).

Dimension O2 (mm)	Ø 20	Ø 25	Ø 32	Ø 40	Ø 50	Ø 63	Dimension O4 (mm)	Ø 20	Ø 25	Ø 32	Ø 40	Ø 50	Ø 63
20 ÷ 30	24	24	24	24	24	28	20 ÷ 30	29	29	33	34	36	38
40 ÷ 100	44	44	48	48	48	52	40 ÷ 100	39	39	45	46	48	50
125 ÷ 200	120	120	124	124	124	128	125 ÷ 200	77	77	83	84	86	88

Ø	A	ØD	E1	E2	F	F1	F2	F3	F4	F5	F6	G1	G2	H	H1	L1	L2	M1	M2	N	O1	O3	P1/P2	P3	Q	R	S	Y	Y1	Y2	Y3	Y4	X1	X2	J	K	
20	10	10	70	18	G1/8	10,5	10,5	25	12,5	11,5	10,5	81	30	72	54	37	53	83	36	24	17	28	M5x0,8	M6x1	13	12	6	28	3	3,5	3	6	5,5	9	5	44	M5
25	10	12	78	26	G1/8	11,5	8	28,5	12,5	13,5	11,5	91	40	82	64	37,5	53,5	93	42	30	17	34	M6x1	M6x1	15	12	6	34	4	4,5	3	6	5,5	9	5	50	M5
32	12	16	96	30	G1/8	12,5	9,5	34	7	15	12,5	110	45	98	78	37,5	59,5	112	48	34	21	42	M8x1,25	M8x1,25	20	16	10	42	4	4,5	3	6	6,5	11	6,5	63	M6
40	12	16	104	30	G1/8	13	12	38	13	18	13	118	45	106	86	44	66	120	54	40	22	50	M8x1,25	M8x1,25	20	16	10	50	4	4,5	3	6	6,5	11	6,5	72	M6
50	15	20	130	40	G1/4	14	11	47	8	21,5	12	146	60	130	110	44	72	148	64	46	24	66	M10x1,5	M10x1,5	22	20	13	66	5	6	4	8	8,5	14	8,5	92	M8
63	15	20	130	50	G1/4	14,5	11,4	55	12	28	14,5	158	70	142	124	49	77	162	78	58	24	80	M10x1,5	M10x1,5	22	20	13	80	5	6	4	8	8,5	14	8,5	110	M10

**QCB: total length (L3), projection (B) and guide columns Ø (ØC)**

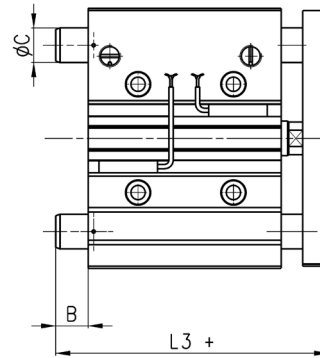

Dimensions L3 and B change according to the different strokes of QCB.  
 For out of standard intermediate strokes (ex. stroke 35), consider the immediately higher stroke dimensions (ex. stroke 40).

Ø	L3 (strokes 20-30 mm)	L3 (strokes 25-50 mm)	L3 (strokes 25-75 mm)	L3 (strokes 40-100 mm)	L3 (strokes 75-100 mm)	L3 (strokes 100-200 mm)	L3 (strokes 125-200 mm)	B (strokes 20-30 mm)	B (strokes 25-50 mm)	B (strokes 25-75 mm)	B (strokes 40-100 mm)	B (strokes 75-100 mm)	B (strokes 100-200 mm)	B (strokes 125-200 mm)	ØC
20	72	-	-	75	-	-	85	19	-	-	22	-	-	32	10
25	74,5	-	-	85,5	-	-	98	21	-	-	32	-	-	44,5	12
32	-	86	-	-	95	-	110	-	26,5	-	-	35,5	-	50,5	16
40	-	86	-	-	95	-	110	-	20	-	-	29	-	44	16
50	-	-	93	-	-	112	-	-	-	21	-	-	40	-	20
63	-	-	93	-	-	112	-	-	-	16	-	-	35	-	20

**QCT: total length (L3), projection (B) and columns Ø (ØC)**

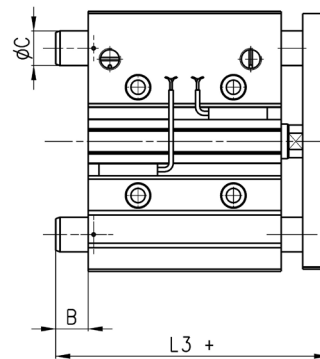

Dimensions L3 and B change according to the different strokes of QCT.  
 For out of standard intermediate strokes (ex. stroke 35), consider the immediately higher stroke dimensions (ex. stroke 40).

Ø	L3 (strokes 20-50 mm)	L3 (stroke 20 mm)	L3 (stroke 25 mm)	L3 (strokes 30-50 mm)	L3 (strokes 25-200 mm)	L3 (strokes 75-200 mm)	L3 (strokes 50-200 mm)	B (strokes 20-50 mm)	B (stroke 20 mm)	B (stroke 25 mm)	B (strokes 30-50 mm)	B (strokes 25-200 mm)	B (strokes 75-200 mm)	B (strokes 50-200 mm)	ØC
20	74,5	-	-	-	-	79,5	-	21,5	-	-	-	-	26,5	-	12
25	-	74,5	-	80,5	-	85	-	-	21	-	27	-	31,5	-	16
32	-	-	73,5	-	-	-	91,5	-	-	14	-	-	-	32	20
40	-	-	73,5	-	-	-	91,5	-	-	7,5	-	-	-	25,5	20
50	-	-	-	-	98,5	-	-	-	-	-	-	26,5	-	-	25
63	-	-	-	-	98,5	-	-	-	-	-	-	21,5	-	-	25

## Magnetic proximity switches with 2- or 3-wire cable for T-slot

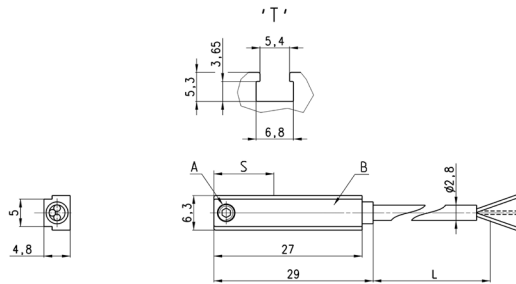
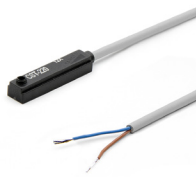

**A = Fixing screw**  
**B = Led indicator**  
**S = Sensing point**  
**L = Length cable**

Mod.	Operation	Connections	Voltage	Output	Max. current	Max Load	Protection	L	S	LED colour
CST-220*	Reed	2 wires	10 ÷ 110 V AC/DC-230 V AC	-	250 mA	10 VA / 8 W	None	2 m	14,5 mm	Yellow
CST-220-5*	Reed	2 wires	10 ÷ 110 V AC/DC-230 V AC	-	250 mA	10 VA / 8 W	None	5 m	14,5 mm	Yellow
CST-220EX	Reed	2 wires	10 ÷ 110 V AC/DC-230 V AC	-	250 mA	10 VA / 8 W	None	2 m	14,5 mm	Yellow
CST-220-5EX	Reed	2 wires	10 ÷ 110 V AC/DC-230 V AC	-	250 mA	10 VA / 8 W	None	5 m	14,5 mm	Yellow
CST-220-12EX	Reed	2 wires	10 ÷ 110 V AC/DC-230 V AC	-	250 mA	10 VA / 8 W	None	12 m	14,5 mm	Yellow
CST-232	Reed	3 wires	5 ÷ 30 V AC/DC	PNP	250 mA	10 VA / 8 W	Against polarity reversing	2 m	14,5 mm	Yellow
CST-232-5	Reed	3 wires	5 ÷ 30 V AC/DC	PNP	250 mA	10 VA / 8 W	Against polarity reversing	5 m	14,5 mm	Yellow
CST-232EX	Reed	3 wires	5 ÷ 30 V AC/DC	PNP	250 mA	10 VA / 8 W	Against polarity reversing	2 m	14,5 mm	Yellow
CST-232-5EX	Reed	3 wires	5 ÷ 30 V AC/DC	PNP	250 mA	10 VA / 8 W	Against polarity reversing and overvoltage	5 m	14,5 mm	Yellow
CST-332	Magneto-resistive	3 wires	10 ÷ 27 V DC	PNP	100 mA	6 W	Against polarity reversing and overvoltage	2 m	7,5 mm	Yellow
CST-332-5	Magneto-resistive	3 wires	10 ÷ 27 V DC	PNP	100 mA	6 W	Against polarity reversing and overvoltage	5 m	7,5 mm	Yellow
CST-332EX	Magneto-resistive	3 wires	10 ÷ 27 V DC	PNP	100 mA	6 W	Against polarity reversing and overvoltage	2 m	7,5 mm	Yellow
CST-332-5EX	Magneto-resistive	3 wires	10 ÷ 27 V DC	PNP	100 mA	6 W	Against polarity reversing and overvoltage	5 m	7,5 mm	Yellow
CST-432	Reed	3 wires	5 ÷ 30 V AC/DC	PNP-NC	250 mA	10 VA / 8 W	Against polarity reversing	2 m	14,5 mm	Yellow
CST-432-5	Reed	3 wires	5 ÷ 30 V AC/DC	PNP-NC	250 mA	10 VA / 8 W	Against polarity reversing	5 m	14,5 mm	Yellow
CST-432EX	Reed	3 wires	5 ÷ 30 V AC/DC	PNP-NC	250 mA	10 VA / 8 W	Against polarity reversing	2 m	14,5 mm	Yellow
CST-432-5EX	Reed	3 wires	5 ÷ 30 V AC/DC	PNP-NC	250 mA	10 VA / 8 W	Against polarity reversing	5 m	14,5 mm	Yellow
CST-532	Hall effect	3 wires	10 ÷ 27 V DC	PNP	100 mA	6 W	Against polarity reversing and overvoltage	2 m	8,5 mm	Yellow
CST-532-5	Hall effect	3 wires	10 ÷ 27 V DC	PNP	100 mA	6 W	Against polarity reversing and overvoltage	5 m	8,5 mm	Yellow
CST-532EX	Hall effect	3 wires	10 ÷ 27 V DC	PNP	100 mA	6 W	Against polarity reversing and overvoltage	2 m	8,5 mm	Yellow
CST-532-5EX	Hall effect	3 wires	10 ÷ 27 V DC	PNP	100 mA	6 W	Against polarity reversing and overvoltage	5 m	8,5 mm	Yellow

\*Mod. CST-220, CST-220-5:  
 in case of polarity reversing the sensor will still be operating, but the LED diode won't turn on.

## Magnetic proximity switches with M8 3-pin connector for T-slot

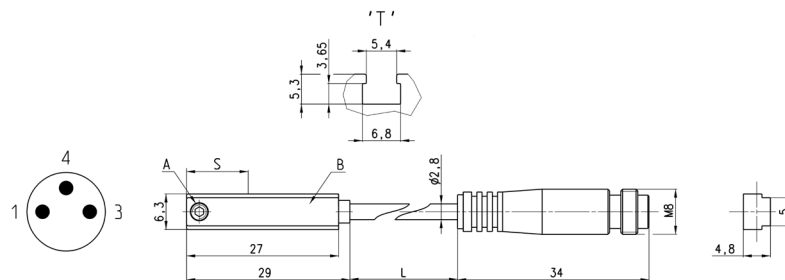

**A = Fixing screw**  
**B = Led indicator**  
**S = Sensing point**  
**L = Length cable**

Mod.	Operation	Connection	Voltage	Output	Max. current	Max Load	Protection	L	S	LED colour
CST-250N*	Reed	2 wires M8 male 3 pin	10 ÷ 110 V AC/DC	-	250 mA	10 VA / 8 W	None	0,3 m	14,5 mm	Yellow
CST-250NEX	Reed	2 wires M8 male 3 pin	10 ÷ 110 V AC/DC	-	250 mA	10 VA / 8 W	None	0,3 m	14,5 mm	Yellow
CST-262	Reed	3 wires M8 male 3 pin	5 ÷ 30 V AC/DC	PNP	250 mA	10 VA / 8 W	Against polarity reversing	0,3 m	14,5 mm	Yellow
CST-262EX	Reed	3 wires M8 male 3 pin	5 ÷ 30 V AC/DC	PNP	250 mA	10 VA / 8 W	Against polarity reversing	0,3 m	14,5 mm	Yellow
CST-362	Magneto-resistive	3 wires M8 male 3 pin	10 ÷ 27 V DC	PNP	100 mA	6 W	Against polarity reversing and overvoltage	0,3 m	7,5 mm	Yellow
CST-362EX	Magneto-resistive	3 wires M8 male 3 pin	10 ÷ 27 V DC	PNP	100 mA	6 W	Against polarity reversing and overvoltage	0,3 m	7,5 mm	Yellow
CST-562	Hall effect	3 wires M8 male 3 pin	10 ÷ 27 V DC	PNP	100 mA	6 W	Against polarity reversing and overvoltage	0,3 m	8,5 mm	Yellow
CST-562EX	Hall effect	3 wires M8 male 3 pin	10 ÷ 27 V DC	PNP	100 mA	6 W	Against polarity reversing and overvoltage	0,3 m	8,5 mm	Yellow

\*Mod. CST-250N:  
 in case of polarity reversing the sensor will still be operating, but the LED diode won't turn on.