

MINI-CYLINDERS

SERIES 16, 23, 24 AND 25

Series 16: Ø 8, 10, 12 mm - non-magnetic
 Series 23: Ø 16, 20, 25 mm - magnetic, auto-cushioned
 Series 24: Ø 10, 12, 16, 20, 25, 32 mm - magnetic
 Series 25: Ø 16, 20, 25, 32 mm - magnetic, cushioned



- Single and double-acting
- In compliance with ISO 6432
- Stainless steel rod and barrel
- Anodized aluminium end-blocks
- Cushioning types:
 - Mechanical with bumper
 - Pneumatic auto-cushioning
 - Adjustable pneumatic cushioning

Series 16, 23, 24 and 25 mini-cylinders are designed according to ISO 6432.

It is possible to choose from three different types of cushioning: mechanical (standard bumper on Series 16 and 24), adjustable pneumatic cushioning (Series 25) and pneumatic auto-cushioning (Series 23).

This last version, thanks to a patented system, automatically adjusts the cushioning in order to provide optimal deceleration during the entire cushioning phase.

The cylinder enjoys smooth, jolt-free movement, reducing vibrations and noise, while also guaranteeing high reliability and constant performance over time.

The adopted technical solutions and the choice of materials have provided the basis for a complete range of versatile and very reliable mini-cylinders.

They are suitable to be used in a multitude of industrial applications, especially where operating conditions undergo changes over time like for example wear of machine components.

Various mounting accessories are available to fix the cylinders in different ways.

General Data

Type of construction	Crimped
Operation	Single-acting and double-acting
Design	ISO 6432 (Ø 8, 10, 12, 16, 20, 25, 32)
Materials	Anodized aluminium end-caps; Stainless steel barrel and rod, aluminium piston; NBR/PU seals, other parts: see the coding example.
Brackets	Rod end Flange Feet Trunnion
Stroke min - max	Ø 8, 10: 10 - 250 mm Ø 12: 10 - 300 mm Ø 16: 10 - 600 mm Ø 20, 25, 32: 10 - 1000 mm
Bores	Series 16: Ø 8, 10, 12 Series 23: Ø 16, 20, 25 Series 24: Ø 10, 12, 16, 20, 25, 32 Series 25: Ø 16, 20, 25, 32
Operating temperature	0°C ÷ 80°C (with dry air -20°C)
Operating pressure	1 ÷ 10 bar (double-acting) 2 ÷ 10 bar (single-acting)
Fluid	Filtered air in class [7:8:4] according to ISO 8573-1. If lubricated air is used, it is recommended to use oil ISOVG32. Once applied the lubrication should never be interrupted.
Speed	10 ÷ 1000 mm/sec (without load)

MINI-CYLINDERS

SERIES 16, 23, 24 AND 25 - STROKES

Standard strokes for minicylinders

- = Double-acting
- ✕ = Single-acting

Series	Ø	10	25	40	50	80	100	125	160	200	250	300	320	400	500
16	10	■ ✕	■ ✕	■ ✕	■ ✕	■	■	■	■	■	■	-	-	-	-
16	12	■ ✕	■ ✕	■ ✕	■ ✕	■	■	■	■	■	■	-	-	-	-
24	10	■	■	■	■	■	■	■	■	■	■	■	■	■	■
24	12	■	■	■	■	■	■	■	■	■	■	■	■	■	■
24	16	■ ✕	■ ✕	■ ✕	■ ✕	■	■	■	■	■	■	■	■	■	■
24	20	■ ✕	■ ✕	■ ✕	■ ✕	■	■	■	■	■	■	■	■	■	■
24	25	■ ✕	■ ✕	■ ✕	■ ✕	■	■	■	■	■	■	■	■	■	■
24	32	■ ✕	■ ✕	■ ✕	■ ✕	■	■	■	■	■	■	■	■	■	■
23/25	16	■	■	■	■	■	■	■	■	■	■	■	■	■	■
23/25	20	■	■	■	■	■	■	■	■	■	■	■	■	■	■
23/25	25	■	■	■	■	■	■	■	■	■	■	■	■	■	■
25	32	■	■	■	■	■	■	■	■	■	■	■	■	■	■

Coding Examples

24	N	2	A	16	A	100
24	SERIES 16 = Non magnetic, with mechanical cushioning 23 = Magnetic, auto-cushioning 24 = Magnetic, with mechanical cushioning 25 = Magnetic, adjustable cushioning					
N	VERSION N = Standard					
2	OPERATION 1 = Single-acting, front spring, no cushion (only for series 16 and 24, Ø 16, 20, 25, 32) 2 = Double-acting 3 = Double-acting, through-rod (excluding series 24, Ø 10, 12) 7 = Single-acting, through-rod (only for series 16 and 24 Ø 16, 20, 25, 32)			PNEUMATIC SYMBOLS CS02 (s. 16) - CS06 (s. 24) CD01 (s. 16) - CD08 (s. 24) - CD23 (s. 23) - CD09 (s. 25) CD05 (s. 16) - CD12 (s. 24) - CD24 (s. 23) - CD13 (s. 25) CS04 (s. 16) - CS10 (s. 24)		
A	MATERIALS A = Rolled stainless steel AISI 303 rod (Ø 32 AISI 420B) - stainless steel AISI 304 tube - anodized AL end-blocks					
16	BORE 08 = 8 mm (only for series 16) 10 = 10 mm (only for series 16 and 24) 12 = 12 mm (only for series 16 and 24) 16 = 16 mm (only for series 23, 24 and 25) 20 = 20 mm (only for series 23, 24 and 25) 25 = 25 mm (only for series 23, 24 and 25) 32 = 32mm (only for series 24 e 25)					
A	CONSTRUCTION TYPE A = Nose nut Mod. V + Piston rod lock nut Mod. U RL = Cylinder with rod lock (only for Ø 20 - Ø 25)					
100	STROKE (See graph)					
	OPTIONS = Standard V = Rod seal in FKM W = All seals in FKM, +130°C (only for series 25: Ø 16, 20, 25)					
	STEM LENGTH = Standard (_ _ _) = Rod extended with _ _ _ mm					
	CERTIFICATIONS = Standard EX = ATEX (only for CONSTRUCTION type A)					

Pneumatic symbols

The pneumatic symbols which have been indicated in the CODING EXAMPLE are shown below.

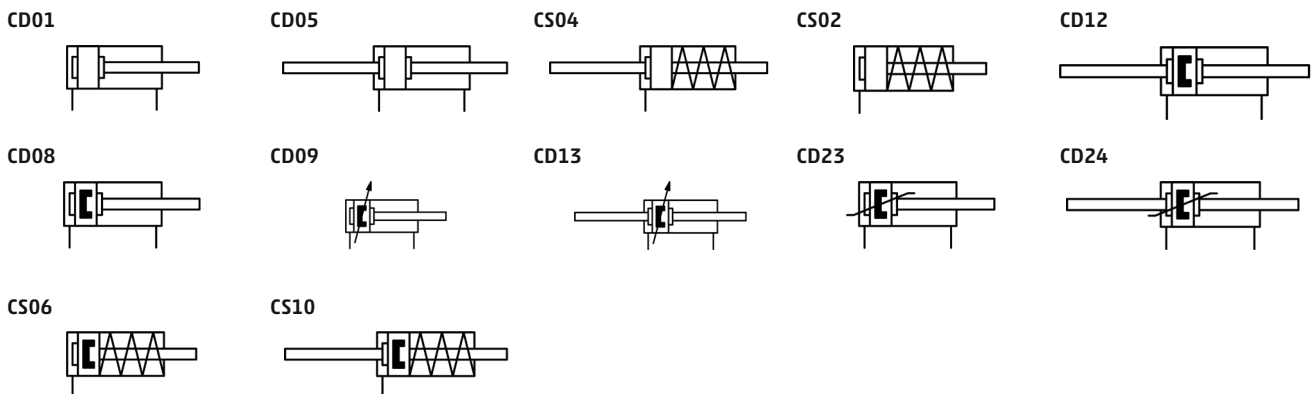

Accessories for minicylinders series 16, 23, 24, 25

Swivel ball joint Mod. GA



Piston rod socket joint Mod. GY



Self aligning rod Mod. GK



Coupling piece Mod. GKF



Piston rod lock nut Mod. U



Nose nut Mod. V



Rear trunnion bracket Mod. I



Foot mount Mod. B



Front/rear flange mount Mod. E



Proximity switches Mod. CST



Proximity switches Mod. CSG

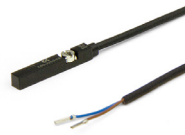

Adapters Mod. S-CST-02



Guides Mod. 45NUT



Guides Mod. 45NHB



Guides Mod. 45NHT



All accessories are supplied separately, except for piston rod lock nut Mod. U and nose nut Mod. V

MINI-CYLINDERS

SERIES 16, 23, 24 AND 25 - DIAGRAMS

Series 16-24: graph showing the loads of the cylinder springs

Check the force of the spring on the graph, according to the size chosen.

F = Force of the spring (N)
 X = Cylinder stroke (mm)

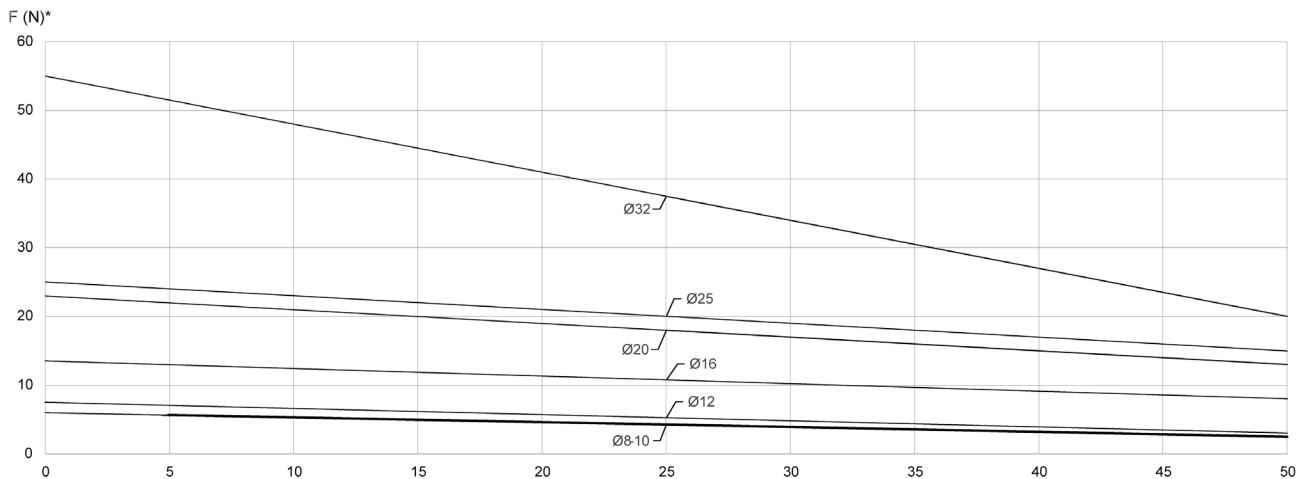
Series 23: applicable mass according to the cylinder's speed

CHOICE OF THE CYLINDER

1. Choose the right size according to the force needed in the application
2. Check on the graph if the working conditions, mass and speed intersect at a point below the curve that corresponds to the size chosen

m = mass applied to the cylinder (kg)
 v = speed applied to the cylinder (m/s)

Example:

Diameter = 20 mm;
 Max speed = 0,4 m/s;
 Applicable mass = 6kg;

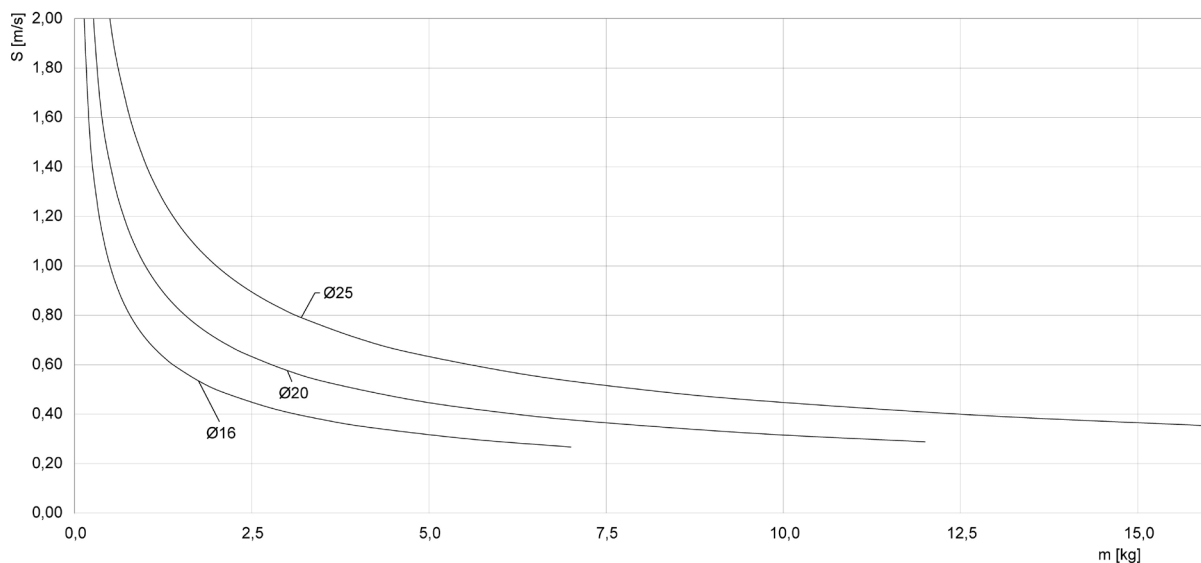

Series 16, 23, 24 and 25 mini-cylinders

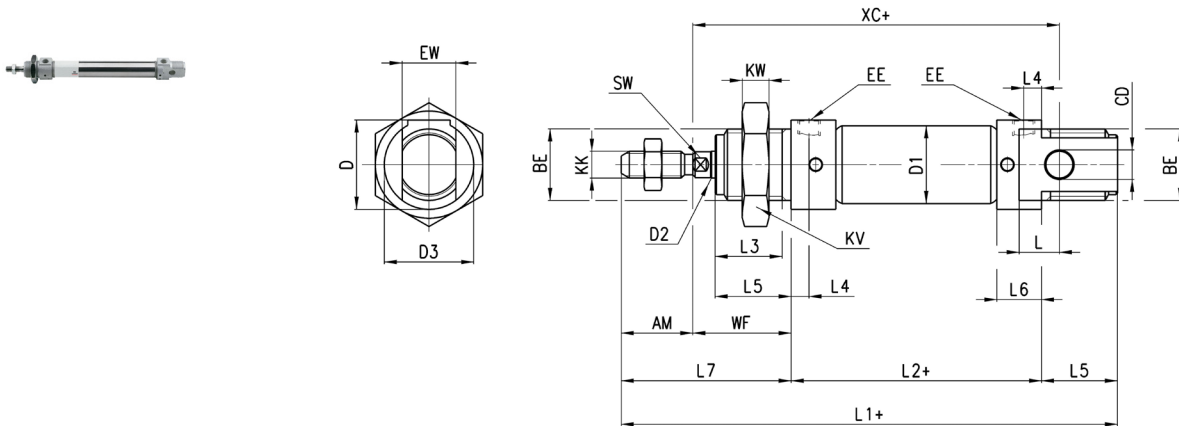

+ = add the stroke

Series	∅	EW	KW	BE	KK	CD	∅D1	EE	∅D2	L1+	XC+	L2+	AM	L3	L4	L5	L	WF	L6	L7	KV	SW	D	D3	Front/rear cushion stroke
16	8	8	7	M12x1,25	M4x0,7	4	9,3	M5	4	86	64	46	12	10	4,5	12	6	16	9	28	19	-	15	15	-
16-24	10	8	7	M12x1,25	M4x0,7	4	11,3	M5	4	86	64	46	12	10	4,5	12	6	16	9	28	19	-	15	15	-
16-24	12	12	8	M16x1,5	M6x1	6	13,3	M5	6	105	75	50	16	15	4,5	17	9	22	9	38	24	5	20,5	20	-
23	16	12	8	M16x1,5	M6x1	6	17,3	M5	6	111	82	56	16	15	5,5	17	9	22	12	38	24	5	20,5	20	10
24-25	16	12	8	M16x1,5	M6x1	6	17,3	M5	6	111	82	56	16	15	5,5	17	9	22	10	38	24	5	20,5	20	10
23-24-25	20	16	10	M22x1,5	M8x1,25	8	21,3	G1/8	8	132	95	68	20	18	8	20	12	24	16	44	32	7	27	15	
23-24-25	25	16	10	M22x1,5	M10x1,25	8	26,5	G1/8	10	141,5	104	69,5	22	20	8	22	12	28	16	50	32	9	27	16	
24-25	32	26	8	M30x1,5	M10x1,25	12	33,6	G1/8	12	139	105	69	20	19	7,5	22	13	28	15	48	-	10	36,5	18	

Series 16, 23, 24 and 25 mini-cylinders with through-rod

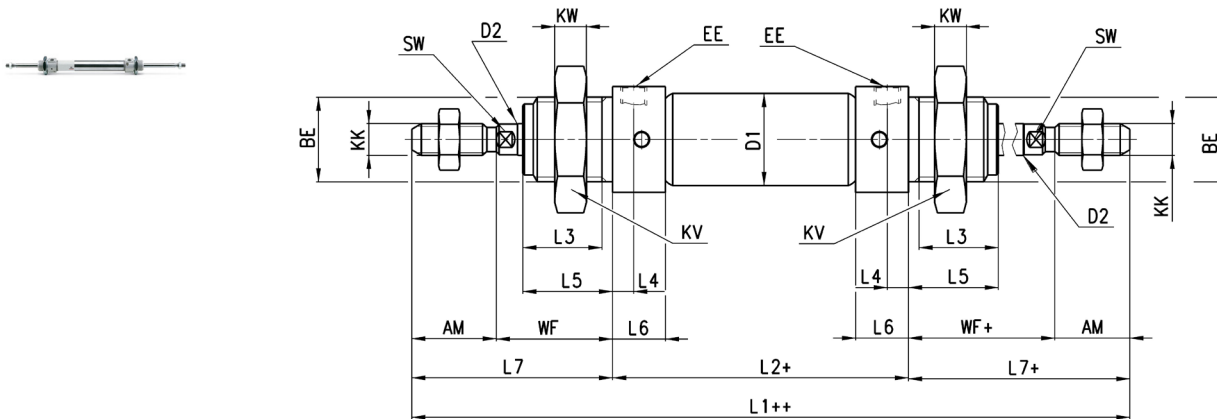

+ = add the stroke once
 ++ = add the stroke twice

Series	∅	KW	BE	KK	∅D1	EE	∅D2	L1++	L2+	AM	L3	L4	L5	WF+	L6	L7+	KV	SW	Front/rear cushion stroke
16	8	7	M12x1,25	M4x0,7	9,3	M5	4	102	46	12	10	4,5	12	16	9	28	19	-	-
16	10	7	M12x1,25	M4x0,7	11,3	M5	4	102	46	12	10	4,5	12	16	9	28	19	-	-
16	12	8	M16x1,5	M6x1	13,3	M5	6	126	50	16	15	4,5	17	22	9	38	24	5	-
23	16	8	M16x1,5	M6x1	17,3	M5	6	132	56	16	15	5,5	17	22	12	38	24	5	10
24-25	16	8	M16x1,5	M6x1	17,3	M5	6	132	56	16	15	5,5	17	22	10	38	24	5	10
23-24-25	20	10	M22x1,5	M8x1,25	21,3	G1/8	8	156	68	20	18	8	20	24	16	44	32	7	15
23-24-25	25	10	M22x1,5	M10x1,25	26,5	G1/8	10	169,5	69,5	22	20	8	22	28	16	50	32	9	16
24-25	32	8	M30x1,5	M10x1,25	33,6	G1/8	12	165	69	20	19	7,5	22	28	15	48	-	10	18

MINI-CYLINDERS

SERIES 16, 23, 24 AND 25 - DIMENSIONS

Series 23 - 24 - 25 mini-cylinders with rod lock (Mod. RLC)

PNEUMATIC ACTUATION

1

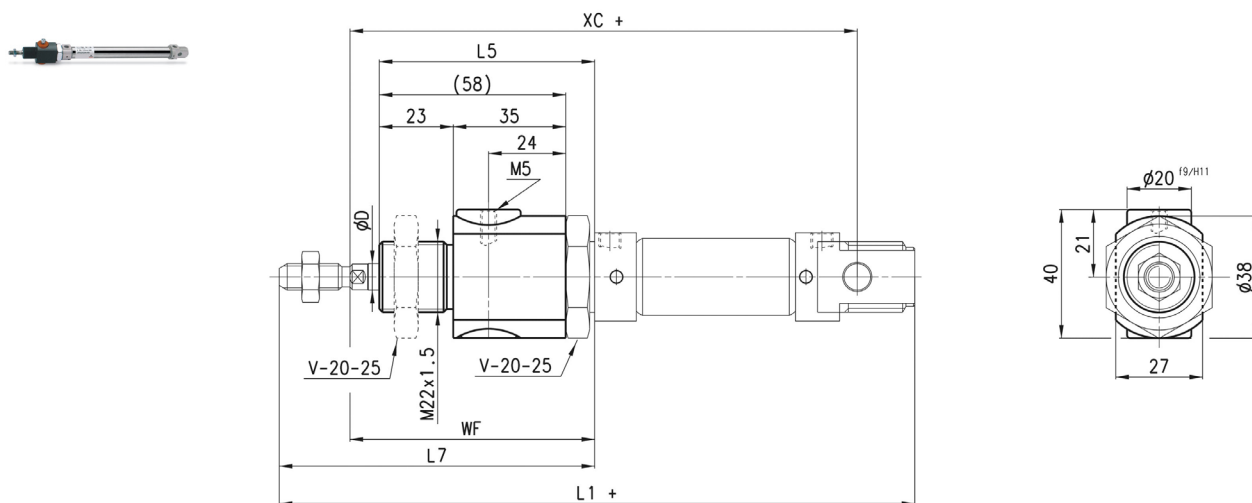

+ = add the stroke

Series	∅	D	WF	L5	L7	XC+	L1 +	F [N]
23-24-25	20	8	74	70	94	145	182	300
23-24-25	25	10	76	70	98	152	189,5	400

Rod fork end Mod. G

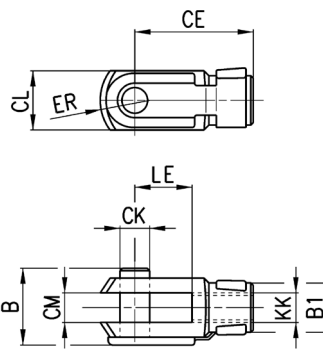

ISO 8140

 Material:
zinc-plated steel

Mod.	∅	CL	ER	CE	B	CM	CK	LE	KK	B1
G-8-10	8-10	8	5	16	11	4	4	8	M4x0,7	8
G-12-16	12-16	12	7	24	16	6	6	12	M6x1	10
G-20	20	16	10	32	22	8	8	16	M8x1,25	14
G-25-32	25-32	20	12	40	26	10	10	20	M10x1,25	18

Swivel ball joint Mod. GA

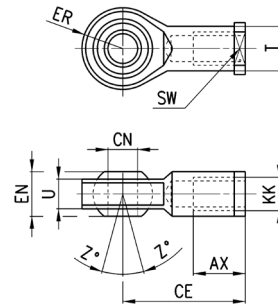

ISO 8139

 Material:
 zinc-plated steel

Mod.	∅	\varnothing_{CN}	U	EN	ER	AX	CE	KK	\varnothing_T	Z	SW
GA-8-10	8-10	5	6	8	9	10	27	M4x0,7	9	6,5°	9
GA-12-16	12-16	6	7	9	10	12	30	M6x1	10	6,5°	11
GA-20	20	8	9	12	12	16	36	M8x1,25	12,5	6,5°	14
GA-32	25-32	10	10,5	14	14	20	43	M10x1,25	15	6,5°	17

Piston rod socket joint Mod. GY

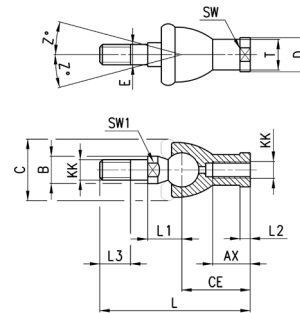
ISO 8139

 Material:
 zama and zinc-plated steel

Mod.	∅	Z	E	SW	\varnothing_T	\varnothing_D	\varnothing_C	\varnothing_B	KK	L3	SW1	L1	L	CE	AX	L2
GY-12-16	12-16	15	6	11	10	13	20	10	M6x1	11	8	12,2	55	28	15	5
GY-20	20	15	8	14	12,5	16	24	12	M8x1,25	12	10	16	65	32	16	5
GY-32	25-32	15	10	17	15	19	28	14	M10x1,25	15	11	19,5	74	35	18	6,5

Self aligning rod Mod. GK

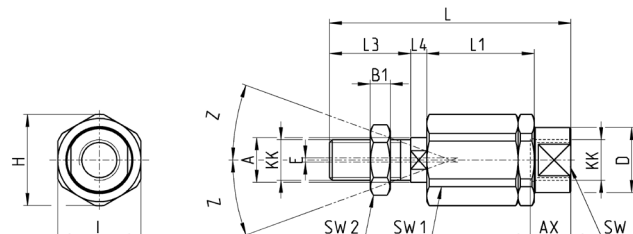
 Material:
 zinc-plated steel

Mod.	∅	H	I	Z	\varnothing_A	KK	E	L	L3	L4	L1	B1	SW2	SW1	AX	SW	\varnothing_D
GK-12-16	12-16	14,5	13	3	6	M6x1	1	35	11	2,5	17,5	4	10	5	12,5	7	8,5
GK-20	20	19	17	4	8	M8x1,25	2	57	21	5	26	4	13	7	16	11	12,5
GK-25-32	25-32	32	30	4	14	M10x1,25	2	71,5	20	7,5	35	5	17	12	22	19	22

MINI-CYLINDERS

SERIES 16, 23, 24 AND 25 - ACCESSORIES

PNEUMATIC ACTUATION

1

Coupling piece Mod. GKF

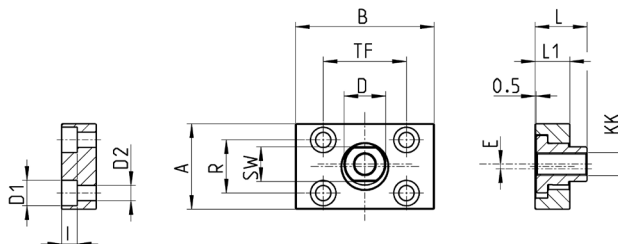

 Material:
zinc-plated steel

Mod.	∅	${}_eD1$	l	∅D2	A	R	SW	B	TF	${}_eD$	E	L	L1	KK
GKF-20	20	5,5	-	-	30	20	13	35	25	14	1,5	22,5	10	M8x1,25
GKF-25-32	25-32	11	6,8	6,6	37	23	15	60	36	18	2	22,5	15	M10x1,25

Piston rod nut Mod. U

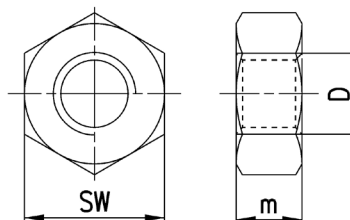

UNI EN ISO 4035

 Material:
zinc-plated steel

Mod.	∅	SW	m	D
U-8-10	8-10	7	3	M4x0,7
U-12-16	12-16	10	4	M6x1
U-20	20	13	5	M8x1,25
U-25-32	25-32	17	6	M10x1,25

Nose nut Mod. V



ISO 4035

 V-8-10 / V-20-25 / V-42-32
not according standard.

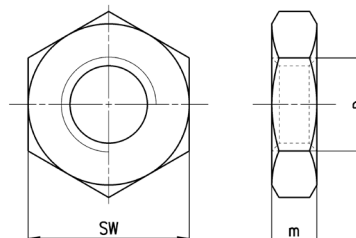
 Material:
zinc-plated steel

Mod.	∅	D	M	SW
V-8-10	8-10	M12x1,25	7	19
V-12-16	20	M16x1,5	8	24
V-20-25	32	M22x1,5	10	32
V-42-32	32	M30x1,5	8	-

Rear trunnion bracket Mod. I



Material:
zinc-plated steel

Supplied with:
2x Seeger
1x female support
1x piston pin

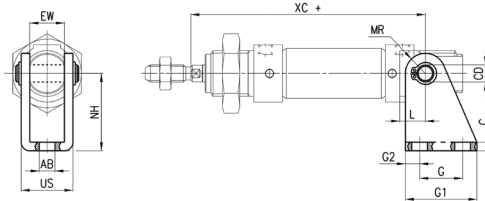

+ = add the stroke

Mod.	∅	EW	US	NH	XC+	MR	L	G2	G	G1	CD	C	
I-8-10	8-10	8	4,5	13,1	24	64	5	6	3,5	12,5	20	4	2,5
I-12-16	12	12	5,5	18,1	27	75	7	9	5	15	25	6	3
I-12-16	16	12	5,5	18,1	27	82	7	9	5	15	25	6	3
I-20-25	20	16	6,6	24,1	30	95	10	12	6	20	32	8	4
I-20-25	25	16	6,6	24,1	30	104	10	12	6	20	32	8	4
I-24-32	32	26	7	34	33	105	11,5	13	7	24	38	12	4

Foot mount Mod. B



Material:
zinc-plated steel

Supplied with:
2x feet
1x nose nut mod. V

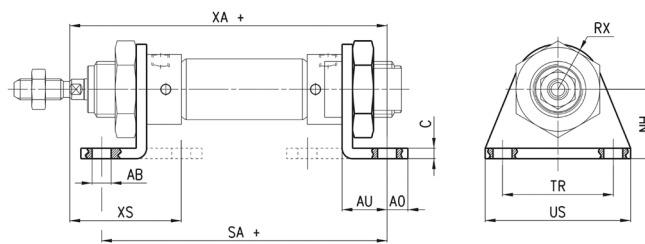

+ = add the stroke

Mod.	∅	∅AB	XS	XA	SA +	AO	AU	C	RX	TR	US	NH
B-8-10	8-10	4,5	24	72,5	67	4,5	10,5	2,5	10	25	35	16
B-12-16	12	5,5	32	82,5	76	6	13	3	13	32	42	20
B-12-16	16	5,5	32	91	82	6	13	3	13	32	42	20
B-20-25	20	6,6	36	108	100	8	16	4	20	40	54	25
B-20-25	25	6,6	40	113,5	101,5	8	16	4	20	40	54	25
B-24-32	32	7	40	113	101	7	16	4	20,5	58	66	28

Front/rear flange mount Mod. E



Material:
zinc-plated steel

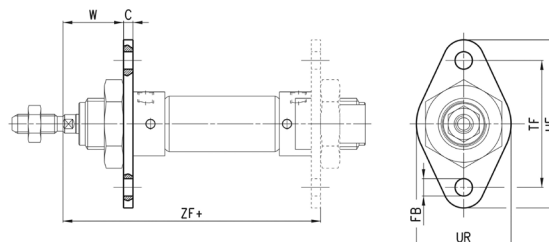

+ = add the stroke

Mod.	∅	W	C	ZF+	FB	UF	TF	UR
E-8-10	8-10	13,5	2,5	64,5	4,5	40	30	25
E-12-16	12	19	3	75	5,5	53	40	30
E-12-16	16	19	3	81	5,5	53	40	30
E-20-25	20	20	4	96	6,6	66	50	40
E-20-25	25	24	4	101,5	6,6	66	50	40
E-24-32	32	23	5	102	6,6	68	52	50

MINI-CYLINDERS

SERIES 16, 23, 24 AND 25 - ACCESSORIES

PNEUMATIC ACTUATION

1

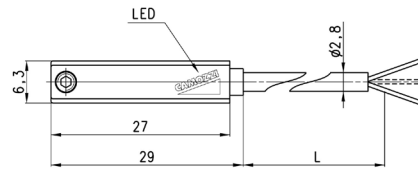
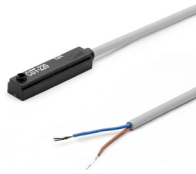
Magnetic proximity switches with 2 or 3 wire cable for T-slot Mod. CST

Further details can be found in the "Proximity switch" chapter.

Mod.	Operation	Connections	Voltage	Output	Max. current	Max Load	Protection	L = length cable
CST-220	Reed	2 wires	10 ÷ 110 V AC/DC-230 V AC	-	250 mA	10 VA / 8 W	None	2 m
CST-220-5	Reed	2 wires	10 ÷ 110 V AC/DC-230 V AC	-	250 mA	10 VA / 8 W	None	5 m
CST-220-12	Reed	2 wires	10 ÷ 110 V AC/DC-230 V AC	-	250 mA	10 VA / 8 W	None	12 m
CST-220EX	Reed	2 wires	10 ÷ 110 V AC/DC-230 V AC	-	250 mA	10 VA / 8 W	None	2 m
CST-220-5EX	Reed	2 wires	10 ÷ 110 V AC/DC-230 V AC	-	250 mA	10 VA / 8 W	None	5 m
CST-220-12EX	Reed	2 wires	10 ÷ 110 V AC/DC-230 V AC	-	250 mA	10 VA / 8 W	None	12 m
CST-232	Reed	3 wires	5 ÷ 30 V AC/DC	PNP	250 mA	10 VA / 8 W	Against polarity reversing	2 m
CST-232-5	Reed	3 wires	5 ÷ 30 V AC/DC	PNP	250 mA	10 VA / 8 W	Against polarity reversing	5 m
CST-232EX	Reed	3 wires	5 ÷ 30 V AC/DC	PNP	250 mA	10 VA / 8 W	Against polarity reversing	2 m
CST-232-5EX	Reed	3 wires	5 ÷ 30 V AC/DC	PNP	250 mA	10 VA / 8 W	Against polarity reversing and overvoltage	5 m
CST-332	Magneto-resistive	3 wires	10 ÷ 27 V DC	PNP	100 mA	6 W	Against polarity reversing and overvoltage	2 m
CST-332-5	Magneto-resistive	3 wires	10 ÷ 27 V DC	PNP	100 mA	6 W	Against polarity reversing and overvoltage	5 m
CST-332EX	Magneto-resistive	3 wires	10 ÷ 27 V DC	PNP	100 mA	6 W	Against polarity reversing and overvoltage	2 m
CST-332-5EX	Magneto-resistive	3 wires	10 ÷ 27 V DC	PNP	100 mA	6 W	Against polarity reversing and overvoltage	5 m
CST-432	Reed	3 wires	5 ÷ 30 V AC/DC	PNP-NC	250 mA	10 VA / 8 W	Against polarity reversing	2 m
CST-432-5	Reed	3 wires	5 ÷ 30 V AC/DC	PNP-NC	250 mA	10 VA / 8 W	Against polarity reversing	5 m
CST-432EX	Reed	3 wires	5 ÷ 30 V AC/DC	PNP-NC	250 mA	10 VA / 8 W	Against polarity reversing	2 m
CST-432-5EX	Reed	3 wires	5 ÷ 30 V AC/DC	PNP-NC	250 mA	10 VA / 8 W	Against polarity reversing	5 m
CST-532	Hall effect	3 wires	10 ÷ 27 V DC	PNP	100 mA	6 W	Against polarity reversing and overvoltage	2 m
CST-532-5	Hall effect	3 wires	10 ÷ 27 V DC	PNP	100 mA	6 W	Against polarity reversing and overvoltage	5 m
CST-532EX	Hall effect	3 wires	10 ÷ 27 V DC	PNP	100 mA	6 W	Against polarity reversing and overvoltage	2 m
CST-532-5EX	Hall effect	3 wires	10 ÷ 27 V DC	PNP	100 mA	6 W	Against polarity reversing and overvoltage	5 m

 Note for 2-wire switches Mod. CST-220, CST-220-5:
 in case of polarity reversing the sensor will still be operating, but the LED diode won't turn on.

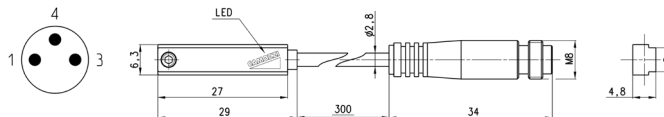
Magnetic proximity switches with M8 3-pin connector for T-slot Mod. CST

Cable length: 0.3 m

Mod.	Operation	Connection	Voltage	Output	Max. current	Max Load	Protection
CST-250N	Reed	2 wires M8 male 3 pin	10 ÷ 110 V AC/DC	-	250 mA	10 VA / 8 W	None
CST-250NEX	Reed	2 wires M8 male 3 pin	10 ÷ 110 V AC/DC	-	250 mA	10 VA / 8 W	None
CST-262	Reed	3 wires M8 male 3 pin	5 ÷ 30 V AC/DC	PNP	250 mA	10 VA / 8 W	Against polarity reversing
CST-262EX	Reed	3 wires M8 male 3 pin	5 ÷ 30 V AC/DC	PNP	250 mA	10 VA / 8 W	Against polarity reversing
CST-362	Magneto-resistive	3 wires M8 male 3 pin	10 ÷ 27 V DC	PNP	100 mA	6 W	Against polarity reversing and overvoltage
CST-362EX	Magneto-resistive	3 wires M8 male 3 pin	10 ÷ 27 V DC	PNP	100 mA	6 W	Against polarity reversing and overvoltage
CST-562	Hall effect	3 wires M8 male 3 pin	10 ÷ 27 V DC	PNP	100 mA	6 W	Against polarity reversing and overvoltage
CST-562EX	Hall effect	3 wires M8 male 3 pin	10 ÷ 27 V DC	PNP	100 mA	6 W	Against polarity reversing and overvoltage

 Note for 2-wire switch Mod. CST-250N:
 in case of polarity reversing the sensor will still be operating, but the LED diode won't turn on.

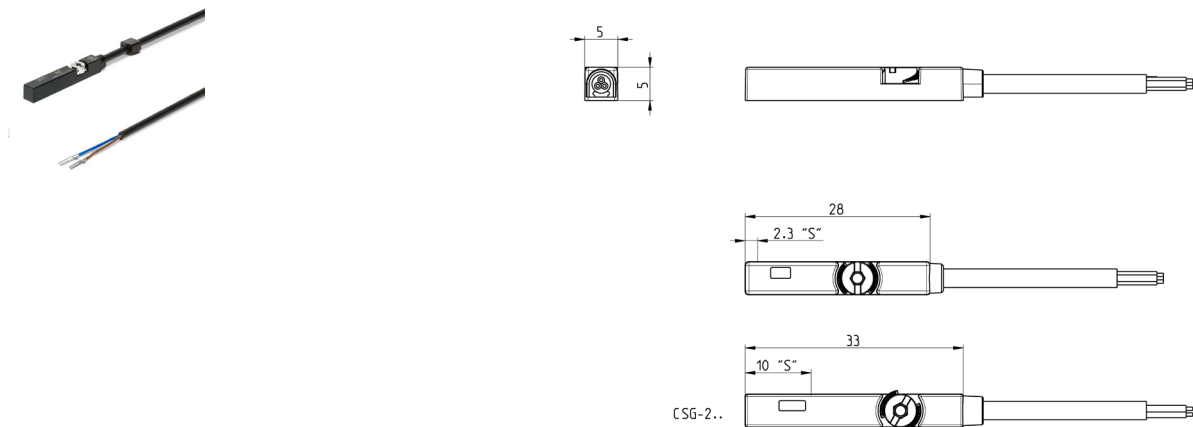
Magnetic proximity switches, ATEX "II 3 GD" certified, T-slot, straight Mod. CSG

Mod.	Operation	Connection	Voltage	Output	Max. current	Max Load	Protection
CSG-223-2-EX	Reed NO	2 wires	5 ÷ 30 V AC/DC	-	100 mA	3 W	IP67
CSG-223-5-EX	Reed NO	2 wires	5 ÷ 30 V AC/DC	-	100 mA	3 W	IP67
CSG-233-2-EX	Reed NO	3 wires	10 ÷ 30 V AC/DC	-	500 mA	10 W	IP67
CSG-233-5-EX	Reed NO	3 wires	10 ÷ 30 V AC/DC	-	500 mA	10 W	IP67
CSG-324-2-EX	Magneto-resistive NO	2 wires	10 ÷ 28 V DC	-	50 mA	1.5 W	IP67
CSG-324-5-EX	Magneto-resistive NO	2 wires	10 ÷ 28 V DC	-	50 mA	1.5 W	IP67
CSG-334-2-EX	Magneto-resistive NO	3 wires	10 ÷ 28 V DC	PNP	200 mA	5.5 W	IP67
CSG-334-5-EX	Magneto-resistive NO	3 wires	10 ÷ 28 V DC	PNP	200 mA	5.5 W	IP67
CSG-534-2-EX	Magneto-resistive NO	3 wires	10 ÷ 28 V DC	NPN	200 mA	5.5 W	IP67
CSG-534-5-EX	Magneto-resistive NO	3 wires	10 ÷ 28 V DC	NPN	200 mA	5.5 W	IP67
CSG-734-2-EX	Magneto-resistive NC	3 wires	10 ÷ 28 V DC	NPN	200 mA	5.5 W	IP67
CSG-734-5-EX	Magneto-resistive NC	3 wires	10 ÷ 28 V DC	NPN	200 mA	5.5 W	IP67
CSG-634-2-EX	Magneto-resistive NC	3 wires	10 ÷ 28 V DC	PNP	200 mA	5.5 W	IP67
CSG-634-5-EX	Magneto-resistive NC	3 wires	10 ÷ 28 V DC	PNP	200 mA	5.5 W	IP67

Note for 2-wire switches Mod. CSG-223-2-EX, CSG-223-5-EX, CSG-324-2-EX, CSG-324-5-EX:
in case of polarity reversing the sensor will still be operating, but the LED diode won't turn on.

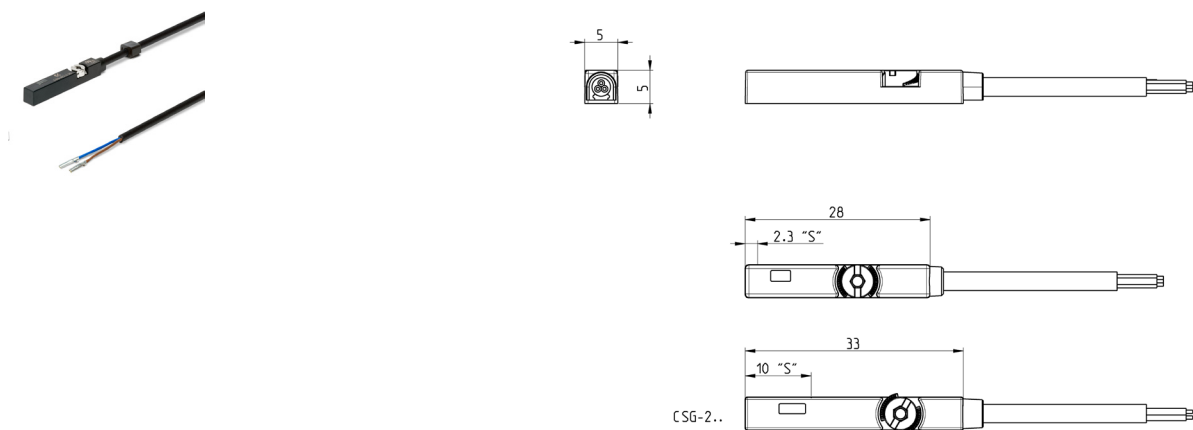
Magnetic proximity switches, UL certified, T-slot, straight Mod. CSG

Mod.	Operation	Connection	Voltage	Output	Max. current	Max. load	Protection
CSG-223-2-UL	Reed	2 wires	5 ÷ 30 V AC/DC	-	60 mA	1.8 W	IP67
CSG-223-5-UL	Reed	2 wires	5 ÷ 30 V AC/DC	-	60 mA	1.8 W	IP67
CSG-223-10-UL	Reed	2 wires	5 ÷ 30 V AC/DC	-	60 mA	1.8 W	IP67
CSG-233-2-UL	Reed	3 wires	10 ÷ 30 V AC/DC	-	100 mA	3 W	IP67
CSG-233-5-UL	Reed	3 wires	10 ÷ 30 V AC/DC	-	100 mA	3 W	IP67
CSG-233-10-UL	Reed	3 wires	10 ÷ 30 V AC/DC	-	100 mA	3 W	IP67
CSG-324-2-UL	Magneto-resistive	2 wires	10 ÷ 28 V DC	-	40 mA	1.2 W	IP67
CSG-324-5-UL	Magneto-resistive	2 wires	10 ÷ 28 V DC	-	40 mA	1.2 W	IP67
CSG-334-2-UL	Magneto-resistive	3 wires	10 ÷ 28 V DC	PNP	100 mA	3 W	IP67
CSG-334-5-UL	Magneto-resistive	3 wires	10 ÷ 28 V DC	PNP	100 mA	3 W	IP67
CSG-534-2-UL	Magneto-resistive	3 wires	10 ÷ 28 V DC	NPN	100 mA	3 W	IP67
CSG-534-5-UL	Magneto-resistive	3 wires	10 ÷ 28 V DC	NPN	100 mA	3 W	IP67

Note for 2-wire switches Mod. CSG-223-2-UL, CSG-223-5-UL, CSG-324-2-UL, CSG-324-5-UL:
in case of polarity reversing the sensor will still be operating, but the LED diode won't turn on.

MINI-CYLINDERS

SERIES 16, 23, 24 AND 25 - ACCESSORIES

Adapters for Series CST-CSG sensors

PNEUMATIC ACTUATION

1

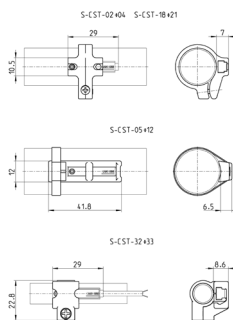

Mod.	Cylinders Series	∅
S-CST-02	23, 24, 25	16
S-CST-03	23, 24, 25	20
S-CST-04	23, 24, 25	25
S-CST-18	23, 24, 25	32
S-CST-32	24	10
S-CST-33	24	12

Further details can be found in the "Proximity switch" chapter.

Guides Mod. 45NUT for cylinders Series 16, 24, 25

Supplied with:
 1x fixing nut

Suitable for cylinders Series 16, 24 and 25 DIN/ISO 6432, ∅ 12 and 16. These guides do not need lubrication. For applicable loads see graph 1.

Cylinders ∅12 and ∅16 use the same guides.

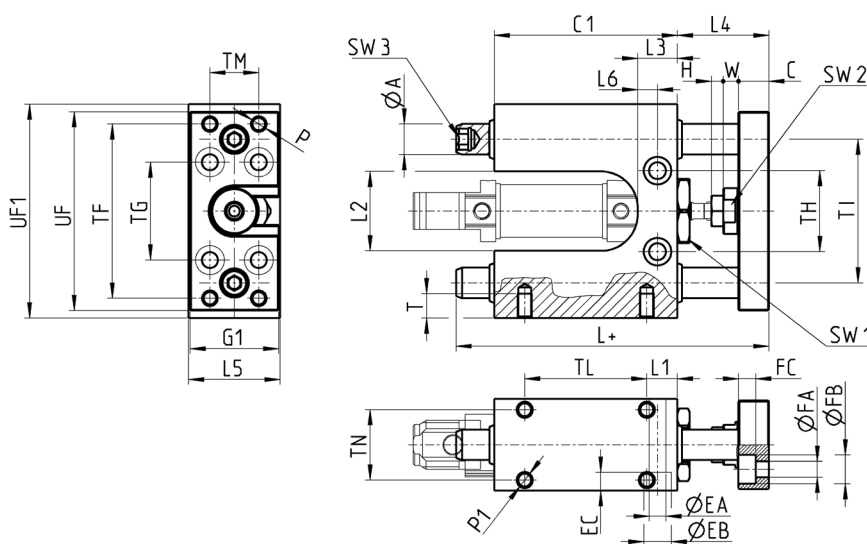

+ = add the stroke

∅	TF	TG	TH	TI	TM	TL	TN	UF1	UF	G1	∅A	C1	H	W	C	L	L1	L2	L3	L4	L5	L6	P	P1	T	∅EA	∅EB	EC	∅FA	∅FB	FC	SW1	SW2	SW3
12	57	32	26,5	47	16	40	23	70	65	29	10	60	4	5	10	102,5	10	26	13	30	30	6,5	M5	M5	8	5,5	9	5,7	5,5	9,5	5,7	21	13	6
16	57	32	26,5	47	16	40	23	70	65	29	10	60	4	5	10	102,5	10	26	13	30	30	6,5	M5	M5	8	5,5	9	5,7	5,5	9,5	5,7	21	13	6

MINI-CYLINDERS

SERIES 16, 23, 24 AND 25 - ACCESSORIES

Guides Mod. 45NHB for cylinders Series 24, 25

PNEUMATIC ACTUATION

Supplied with:
 1x fixing nut

Suitable for cylinders Series 24 and 25 DIN/ISO 6432, Ø20 and 25.

To lubricate these guides, use the special lubricator. For applicable loads see graph 2.

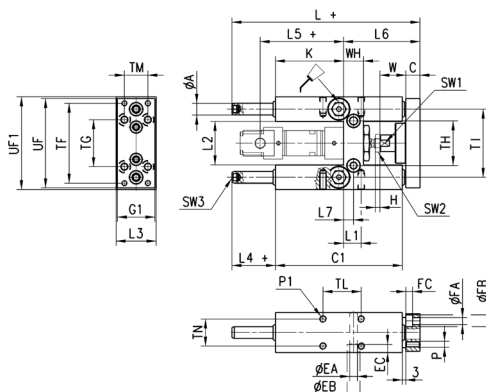
1

+ = add the stroke

Ø	TF	TG	TH	TI	TL	TM	TN	UF	G1	UF1	A	WH	C1	H	W	C	K	L	L1	L2	L3	L4	L5	L6	L7	P	P1	T	ØEA	ØEB	EC	ØFA	ØFB	FC	SW1	SW2	SW3
20	68	40	38	58	32,5	20	23	76	32	79	10	17	108	4	22	12	58	160	15	37	34	37	71	65	8,5	M5	M6	14	6,5	11	6,8	5,5	10	5,7	13	13	6
25	68	40	38	58	32,5	20	23	76	32	79	10	17	108	6	17	12	58	160	15	37	34	37	76	65	8,5	M5	M6	14	6,5	11	6,8	5,5	10	5,7	13	17	6