

# Control Valve 8043

## with integrated positioner

### GS3 series DN 15 up to DN 250

**Pneumatic control valve with integrated positioner for control of neutral and aggressive fluids in process engineering, chemical industry and for plant equipment.**

- Integrated positioner
- Lowest possible weight
- Fast response
- High Kvs- (Cv)- values
- Tight shut - off

#### Technical Information

Body design	flangeless, wafer-type construction for flanges acc. DIN EN 1092-1 Form B or ASME B16.5 RF further versions see data-sheet 8020-GS1		
Nominal sizes	DN 15 - 100, 1/2" - 4"		
Nominal pressure acc. EN 1333	PN 40 (fits also to PN 10-25)	DN 15 - DN 150	
	PN 16	DN 200 - DN 250	
Nominal pressure acc. ASME B16.34	ANSI 150	DN 15 - DN 250	
	ANSI 300	DN 15 - DN 150	
nominal pressure acc. JIS for raised face flanges	10K	DN 15 - DN 50	
	20K	DN 15 - DN 40	
Fluid temperature	Versions from -60°C up to +350°C		
Ambient temperature*	-30°C up to +100°C		
Rangeability / Characteristic analog positioner	25 : 1		
	digital positioner		
Leakage	Disc pair Carbon-stainless steel	Disc pair SFC	Disc pair STN 2
	% of Kvs IEC 60534-4 EN 12266-1	< 0,0001 IV-S1 D	< 0,0005 IV-S1 E
Specific leakage rate shaft and body sealing	ISO FE-BH-CC3-SSA0-t(-40°C/+350°C)-PN40-ISO 15848-1		

\* Please consider the limitation of use of the positioner!

\*\* With DN15 with reduction of less than 25%, different leakage rates possible. Kvs-values see data sheet 8001.



#### Options

- stainless steel bellows
- external i/p-converter
- position indicator

#### Fluid temperature

Rating	PN40	PN 16	PN 100	ANSI 150	ANSI 300	ANSI 600
<b>Body material cpl. stainless steel</b>						
Tmin [°C]	-60	-60	-60	-29	-29	-29
Tmax [°C]	350	350	350	350	350	350
<b>Body material cpl. carbon steel</b>						
Tmin [°C]	-60	-60	-10	-20	-20	-10
Tmax [°C]	300	300	300	300	300	300
<b>Body material carbon steel with stainless steel body cover</b>						
Tmin [°C]	-60	-60	-10	-20	-20	-20
Tmax [°C]	350	350	350	350	350	350

#### Positioner

For technical information of our positioners please refer to the corresponding data sheets.

# Control Valve 8043-GS3



with integrated positioner

## Materials

Body	stainless steel 1.4581 or 1.4404 /1.4408	carbon steel 1.0619 / 1.0570	
Intermediate pipe	stainless steel 1.4571	carbon steel 1.0570	
Bonnet	brass plated (actuator ø 50 mm, ø 80 mm) aluminium corrosion proofed (actuator ø 125 mm)		
Springs	stainless steel 1.4301 (actuator ø 50 mm, ø 80 mm) spring steel wire C, coated (actuator ø 125 mm)		
Packing	PTFE carbon filled (spring 1.4310)		
Actuating stem	stainless steel, roller burnished		
Bellow	stainless steel 1.4571		
Fixed plate	Stainless steel 1.4571, plated	STN2-disc	
Sliding disc	standard: special carbon material	SFC-disc (max. +300°C)	STN2-disc
Coupling ring for discs	stainless steel 1.4581		
Optical position indicator	PA Trogamid (transparent)		

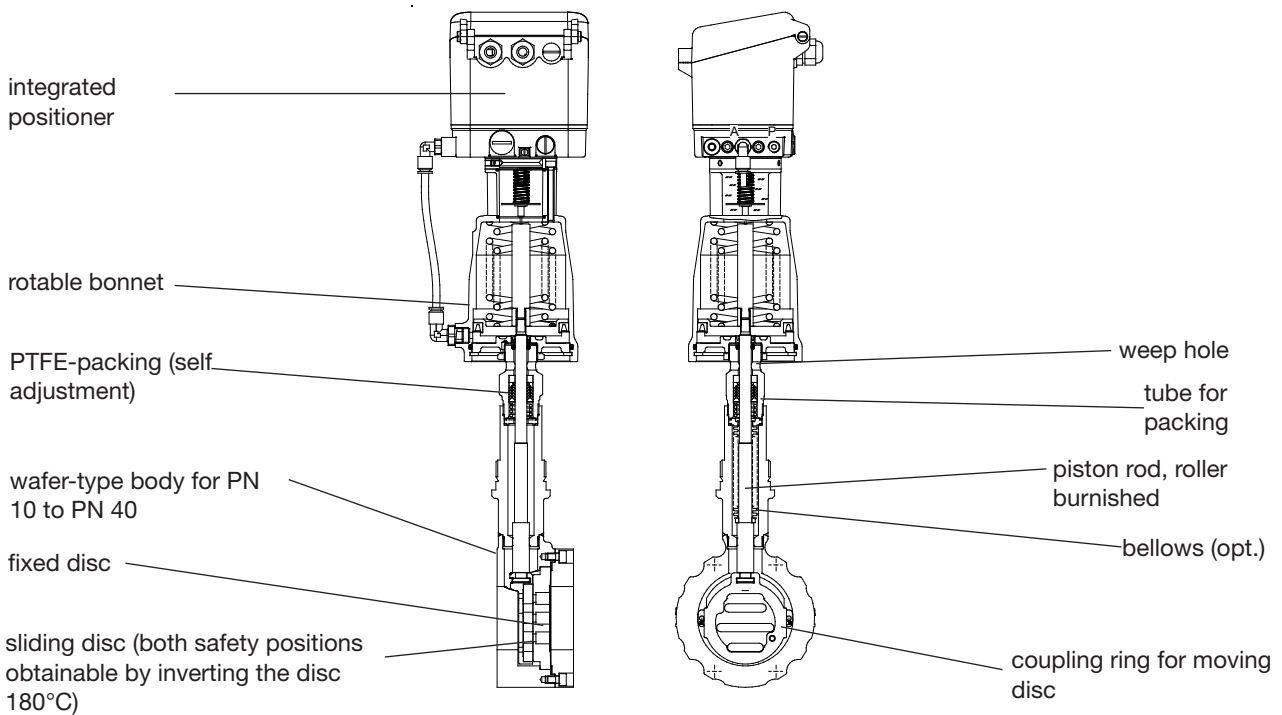

# Control Valve 8043-GS3



with integrated positioner

**Admissible differential pressures**  
**(For temperatures of up to 120°C with PN-rating**  
**up to 38°C with ANSI-rating)**  
**digital positioner, Type 8049**

**For temperatures of 120°C (PN)**  
**or 38°C (ANSI) and above:**  
**obey application limits !**

**(also on-off valves and valves with other side-mounted positioner)**

disc-pair: carbon - stainless steel coated

disc pair: STN2

SFC - stainless steel coated

DN	actuator	max. differential pressure		min. pilot pressure (bar)
		control, on/off (bar)	on/off (bar)	
15	80	51,1		3,0 - 6
20	80	51,1		3,0 - 6
25	80	50,9		3,5 - 6
32	80	40,9		3,5 - 6
40	80	30,4		4,0 - 6
50	80	19,5		4,5 - 6
65	80	16,3		4,5 - 6
80	80	10,2		5,0 - 6
100	80	6,5		5,0 - 6
125	80	4,4		5,0 - 6
150	80	3,3		5,0 - 6

DN	actuator	max. differential pressure		min. pilot pressure (bar)
		control, on/off (bar)	on/off (bar)	
15	80	49,6		3,5 - 6
20	80	37,3		4,0 - 6
25	80	27,4		4,0 - 6
32	80	20,1		4,5 - 6
40	80	13,6		4,5 - 6
50	80	8		5,0 - 6
65	80	6,6		5,0 - 6
80	80	4		5,0 - 6
100	80	2,4		5,0 - 6
125	80	-		-
150	80	-		-

15	125	51,1		2,5 - 6
20	125	51,1		2,5 - 6
25	125	51,1		2,5 - 6
32	125	51,1		3,0 - 6
40	125	51,1		3,0 - 6
50	125	44,9		3,5 - 6
65	125	37,6		3,5 - 6
80	125	23,6		4,0 - 6
100	125	15		4,0 - 6
125	125	10,1		4,0 - 6
150	125	7,5		4,0 - 6
200	125	4,4		4,0 - 6
250	125	2,7		4,0 - 6

15	125	51,1		2,5 - 6
20	125	51,1		3,0 - 6
25	125	51,1		3,0 - 6
32	125	46,2		3,5 - 6
40	125	31,3		3,5 - 6
50	125	18,5		4,0 - 6
65	125	15,1		4,0 - 6
80	125	9,1		4,0 - 6
100	125	5,6		4,0 - 6
125	125	3,8		4,0 - 6
150	125	2,8		4,0 - 6
200	125	-		-
250	125	-		-

	Upper limits for admissible pressures in bar			
	PN16	PN40	ANSI150	ANSI 300
P max. carbon steel	16	40	19,6	51,1
P max. stainless steel			19,0	49,6

## p/p- and i/p-positioner, Type 8047

disc-pair: carbon - stainless steel coated

disc pair: STN2

SFC - stainless steel coated

DN	actuator	max. differential pressure		min. pilot pressure (bar)
		control, on/off (bar)	on/off (bar)	
15	80	51,1	42,2	3,0 - 6
20	80	39,8	36,6	3,0 - 6
25	80	29,5	30,7	3,5 - 6
32	80	21,8	25,1	4,0 - 6
40	80	14,9	19	4,0 - 6
50	80	8,8	12,5	4,5 - 6
65	80	7,2	10,5	4,5 - 6
80	80	4,4	6,7	4,5 - 6
100	80	2,7	4,3	4,5 - 6

DN	actuator	max. differential pressure		min. pilot pressure (bar)
		control (bar)	on/off (bar)	
15	80	28,4	29,9	3,5 - 6
20	80	19,3	23	4,0 - 6
25	80	13,1	17,2	4,0 - 6
32	80	9,1	12,8	4,0 - 6
40	80	5,9	8,8	4,0 - 6
50	80	3,4	5,3	4,5 - 6
65	80	2,7	4,3	4,5 - 6
80	80	-	-	-
100	80	-	-	-

15	125	51,1	51,1	3,0 - 6
20	125	51,1	51,1	3,0 - 6
25	125	51,1	51,1	3,0 - 6
32	125	50,2	51,1	3,0 - 6
40	125	34,3	41,3	3,0 - 6
50	125	20,4	27,1	3,5 - 6
65	125	16,7	22,8	3,5 - 6
80	125	10,1	14,5	3,5 - 6
100	125	6,2	9,3	3,5 - 6
125	125	4,2	6,3	3,5 - 6
150	125	3,1	4,7	3,5 - 6

15	125	51,1	51,1	3,0 - 6
20	125	44,4	50,1	3,0 - 6
25	125	30,2	37,4	3,0 - 6
32	125	21	27,8	3,0 - 6
40	125	13,7	19,1	3,0 - 6
50	125	7,8	11,4	3,5 - 6
65	125	6,3	9,4	3,5 - 6
80	125	3,7	5,7	3,5 - 6
100	125	2,3	3,5	3,5 - 6
125	125	-	-	-
150	125	-	-	-

	Upper limits for admissible pressures in bar			
	PN16	PN40	ANSI150	ANSI 300
P max. carbon steel	16	40	19,6	51,1
P max. stainless steel			19,0	49,6

# Control Valve 8043-GS3



with integrated positioner

**Admissible differential pressures**  
 (For temperatures of up to 120°C with PN-rating  
 up to 38°C with ANSI-rating)

**For temperatures of 120°C (PN)  
 or 38°C (ANSI) and above:  
 obey application limits !**

**Actuator D80 double acting**  
**without safety position**  
**digital positioner, type 8049-4 wire**

Nominal size	Max. differential pressure at actual pilot pressure [bar]															
	Disc pair: carbon/SFC-stainless steel coated								Disc pair: STN							
	2,5	3,0	3,5	4,0	4,5	5,0	5,5	6,0	2,5	3,0	3,5	4,0	4,5	5,0	5,5	6,0
15	51,1	51,1	51,1	51,1	51,1	51,1	51,1	51,1	51,1	51,1	51,1	51,1	51,1	51,1	51,1	51,1
20	51,1	51,1	51,1	51,1	51,1	51,1	51,1	51,1	46,3	51,1	51,1	51,1	51,1	51,1	51,1	51,1
25	51,1	51,1	51,1	51,1	51,1	51,1	51,1	51,1	34,0	41,8	49,6	51,1	51,1	51,1	51,1	51,1
32	50,8	51,1	51,1	51,1	51,1	51,1	51,1	51,1	24,9	30,7	36,4	42,2	47,9	51,1	51,1	51,1
40	37,7	46,4	51,1	51,1	51,1	51,1	51,1	51,1	16,9	20,8	24,7	28,6	32,5	36,4	40,3	44,2
50	24,2	29,8	35,4	41,0	46,6	51,1	51,1	51,1	10,0	12,3	14,6	16,9	19,2	21,5	23,8	26,1
65	20,2	24,9	29,6	34,3	39,0	43,6	48,3	51,1	8,1	10,0	11,9	13,8	15,7	17,6	19,4	21,3
80	12,7	15,7	18,6	21,5	24,5	27,4	30,4	33,3	4,9	6,0	7,2	8,3	9,4	10,6	11,7	12,8
100	8,1	9,9	11,8	13,7	15,5	17,4	19,3	21,1	3,0	3,7	4,4	5,1	5,8	6,5	7,2	7,9
125	5,5	6,7	8,0	9,2	10,5	11,8	13,0	14,3	2,0	2,5	3,0	3,4	3,9	4,4	4,8	5,3
150	4,1	5,0	5,9	6,9	7,8	8,7	9,7	10,6	1,5	1,8	2,2	2,5	2,9	3,2	3,6	3,9
200	2,3	2,9	3,4	4,0	4,5	5,1	5,6	6,1	-	-	-	-	-	-	-	-
250	1,4	1,8	2,1	2,4	2,8	3,1	3,4	3,8	-	-	-	-	-	-	-	-

	Upper limits for admissible pressures in bar			
	PN16	PN40	ANSI150	ANSI 300
P max. carbon steel	16	40	19,6	51,1
P max. stainless steel			19,0	49,6

**Actuator D125 double acting**  
**without safety position**  
**digital positioner, type 8049-4 wire**

Nominal size	Max. differential pressure at actual pilot pressure [bar]															
	Disc pair: carbon/SFC-stainless steel coated								Disc pair: STN							
	2,5	3,0	3,5	4,0	4,5	5,0	5,5	6,0	2,5	3,0	3,5	4,0	4,5	5,0	5,5	6,0
15	51,1	51,1	51,1	51,1	51,1	51,1	51,1	51,1	51,1	51,1	51,1	51,1	51,1	51,1	51,1	51,1
20	51,1	51,1	51,1	51,1	51,1	51,1	51,1	51,1	51,1	51,1	51,1	51,1	51,1	51,1	51,1	51,1
25	51,1	51,1	51,1	51,1	51,1	51,1	51,1	51,1	51,1	51,1	51,1	51,1	51,1	51,1	51,1	51,1
32	51,1	51,1	51,1	51,1	51,1	51,1	51,1	51,1	51,1	51,1	51,1	51,1	51,1	51,1	51,1	51,1
40	51,1	51,1	51,1	51,1	51,1	51,1	51,1	51,1	44,6	51,1	51,1	51,1	51,1	51,1	51,1	51,1
50	51,1	51,1	51,1	51,1	51,1	51,1	51,1	51,1	26,3	32,0	37,7	43,4	49,0	51,1	51,1	51,1
65	51,1	51,1	51,1	51,1	51,1	51,1	51,1	51,1	21,5	26,2	30,8	35,4	40,1	44,7	49,4	51,1
80	33,6	40,8	48,0	48,0	48,0	48,0	48,0	48,0	12,9	15,7	18,5	21,3	24,1	26,9	29,7	32,5
100	21,3	25,9	30,5	33,0	33,0	33,0	33,0	33,0	8,0	9,7	11,5	13,2	14,9	16,6	18,4	20,1
125	14,4	17,5	20,6	23,0	23,0	23,0	23,0	23,0	5,3	6,5	7,6	8,8	9,9	11,1	12,2	13,4
150	10,7	13,0	15,3	16,0	16,0	16,0	16,0	16,0	3,9	4,8	5,6	6,5	7,3	8,2	9,0	9,9
200	6,2	7,5	8,9	10,2	11,5	12,9	14,2	15,5	-	-	-	-	-	-	-	-
250	3,8	4,6	5,5	6,3	7,1	7,9	8,7	9,6	-	-	-	-	-	-	-	-

	Upper limits for admissible pressures in bar			
	PN16	PN40	ANSI150	ANSI 300
P max. carbon steel	16	40	19,6	51,1
P max. stainless steel			19,0	49,6

# Control Valve 8043-GS3



with integrated positioner

## Application limitations for GS3 valves in stainless steel

These pressure must not be exceeded for GS-valves from the GS3-series made of stainless steel, even though the actuator power might allow it.

### PN40

DN	Sliding unit: carbon/SFC - stainless steel, coated						Sliding unit: STN2					
	max. admissible pressures for GS3-valves in stainless steel						max. admissible pressures for GS3-valves in stainless steel					
	100°C	150°C	200°C	250°C	300°C	350°C	100°C	150°C	200°C	250°C	300°C	350°C
15-32	40	40	40	40	40	40	40	40	40	40	40	40
40	40	40	40	40	40	40	40	40	40	40	37	37
50	40	40	40	40	40	40	40	40	40	40	40	40
65	40	40	40	40	40	40	40	40	40	37	32	32
80	40	40	40	40	40	40	36	34	33	26	22	19
100	33	33	33	33	33	33	32	31	30	24	20	17
125	23	23	23	23	23	23	21	21	19	16	13	11
150	16	16	16	16	16	16	15	15	14	11	9	8
200 (only PN16)	16	16	15	13	12	11	-	-	-	-	-	-
250 (only PN16)	10	9	9	8	7	6	-	-	-	-	-	-

Limitation for SFC-sliding discs: 300°C

### ANSI150

DN	Sliding unit: carbon/SFC - stainless steel, coated								Sliding unit: STN2							
	max. admissible pressures for GS3-valves in stainless steel								max. admissible pressures for GS3-valves in stainless steel							
	38°C	50°C	100°C	150°C	200°C	250°C	300°C	350°C	38°C	50°C	100°C	150°C	200°C	250°C	300°C	350°C
15-125	19,0	18,4	16,2	14,8	13,7	12,1	10,2	8,4	19,0	18,4	16,2	14,8	13,7	12,1	10,2	8,4
150	16,0	16,0	16,0	14,8	13,7	12,1	10,2	8,4	16,2	16,2	16,2	14,8	13,7	11,8	9,7	8,4
200	16,0	16,0	16,0	14,8	13,7	12,1	10,2	8,4	-	-	-	-	-	-	-	-
250	10,4	10,4	10,4	9,9	9,4	8,4	7,4	6,8	-	-	-	-	-	-	-	-

Limitation for SFC-sliding discs: 300°C

### ANSI300

DN	Sliding unit: carbon/SFC - stainless steel, coated								Sliding unit: STN2							
	max. admissible pressures for GS3-valves in stainless steel								max. admissible pressures for GS3-valves in stainless steel							
	38°C	50°C	100°C	150°C	200°C	250°C	300°C	350°C	38°C	50°C	100°C	150°C	200°C	250°C	300°C	350°C
15-65	49,6	48,1	42,2	38,5	35,7	33,4	31,6	30,3	49,6	48,1	42,2	38,5	35,7	33,4	31,6	30,3
80	48,0	48,0	42,2	38,5	35,7	33,4	31,6	30,3	36,6	36,6	36,6	34,8	33,0	26,8	22,0	19,0
100	33,0	33,0	33,0	33,0	33,0	33,0	31,6	30,3	33,0	33,0	33,0	31,7	30,1	24,4	20,1	17,3
125	23,0	23,0	23,0	23,0	23,0	23,0	23,0	23,0	22,0	22,0	22,0	21,0	19,9	16,1	13,2	11,5
150	16,0	16,0	16,0	16,0	16,0	16,0	16,0	16,0	16,0	16,0	16,0	15,4	14,6	11,8	9,7	8,4

Limitation for SFC-sliding discs: 300°C

with integrated positioner

## Application limitations for GS3 valves in carbon steel

These pressure must not be exceeded for GS-valves from the GS3-series made of carbon steel, even though the actuator power might allow it.

### PN40

DN	Sliding unit: carbon/SFC - stainless steel, coated						Sliding unit: STN2					
	max. admissible pressures for GS3-valves in carbon steel						max. admissible pressures for GS3-valves in carbon steel					
	100°C	150°C	200°C	250°C	300°C	350°C	100°C	150°C	200°C	250°C	300°C	350°C
15-50	40	40	40	40	40	40	40	40	40	40	40	40
65	40	40	40	40	40	40	40	40	40	37	32	32
80	40	40	40	40	40	40	36	34	33	26	22	19
100	33	33	33	33	33	33	33	31	30	24	20	17
125	23	23	23	23	23	23	22	21	19	16	13	11
150	16	16	16	16	16	16	16	15	14	11	9	8
200 (nur PN 16)	16	16	15	13	12	11	-	-	-	-	-	-
250 (nur PN 16)	10	9	9	8	7	6	-	-	-	-	-	-

Limitation for SFC-sliding discs: 300°C

### ANSI150

DN	Sliding unit: carbon/SFC - stainless steel, coated								Sliding unit: STN2							
	max. admissible pressures for GS3-valves in carbon steel								max. admissible pressures for GS3-valves in carbon steel							
	38°C	50°C	100°C	150°C	200°C	250°C	300°C	350°C	38°C	50°C	100°C	150°C	200°C	250°C	300°C	350°C
15-125	19,6	19,2	17,7	15,8	13,8	12,1	10,2	8,4	19,6	19,2	17,7	15,8	13,8	12,1	10,2	8,4
150	16,0	16,0	16,0	15,8	13,8	12,1	10,2	8,4	16,2	16,2	16,2	15,4	13,8	11,8	9,7	8,0
200	16,0	16,0	16,0	15,8	13,8	12,1	10,2	8,4	-	-	-	-	-	-	-	-
250	10,5	10,5	10,5	9,9	9,4	8,4	7,4	6,0	-	-	-	-	-	-	-	-

Limitation for SFC-sliding discs: 300°C

### ANSI300

DN	Sliding unit: carbon/SFC - stainless steel, coated								Sliding unit: STN2							
	max. admissible pressures for GS3-valves in carbon steel								max. admissible pressures for GS3-valves in carbon steel							
	38°C	50°C	100°C	150°C	200°C	250°C	300°C	350°C	38°C	50°C	100°C	150°C	200°C	250°C	300°C	350°C
15-50	51,1	50,1	46,6	45,1	43,8	41,9	19,8	40,0	51,1	50,1	46,6	45,1	43,8	41,9	19,8	37,6
65	51,1	50,1	46,6	45,1	43,8	41,9	19,8	40,0	41,7	41,7	41,7	39,7	37,6	33,5	19,8	32,5
80	48,0	48,0	46,6	45,1	43,8	41,9	19,8	40,0	36,6	36,6	36,6	34,8	33,0	26,8	19,8	19,0
100	33,0	33,0	33,0	33,0	33,0	33,0	19,8	33,0	33,0	33,0	33,0	31,7	30,1	24,4	19,8	17,0
125	23,0	23,0	23,0	23,0	23,0	23,0	19,8	23,0	22,1	22,1	22,1	21,0	19,9	16,1	13,2	11,0
150	16,0	16,0	16,0	16,0	16,0	16,0	16,0	16,0	16,0	16,0	16,0	15,4	14,6	11,8	9,7	8,0

Limitation for SFC-sliding discs: 300°C



# Control Valve 8043-GS3

with integrated positioner



## Dimensions and Weights

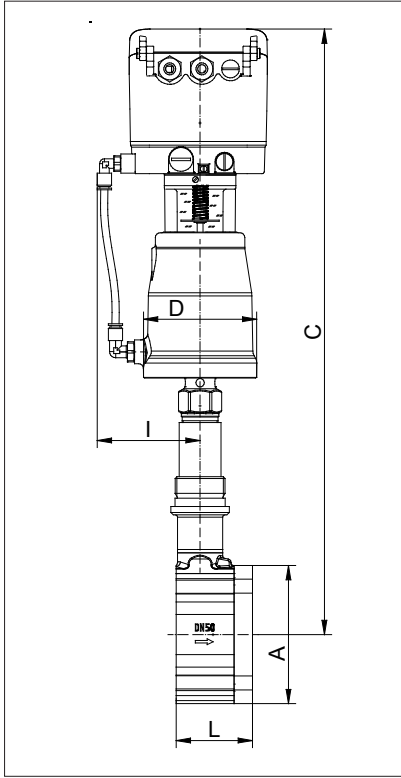

Type 8043 with digital positioner  
Type 8049  
with position indicator

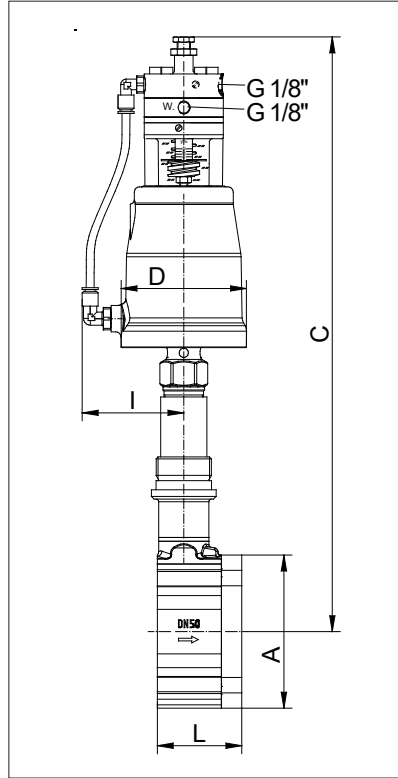

Type 8043 with p/p-positioner  
Type 8047  
with position indicator

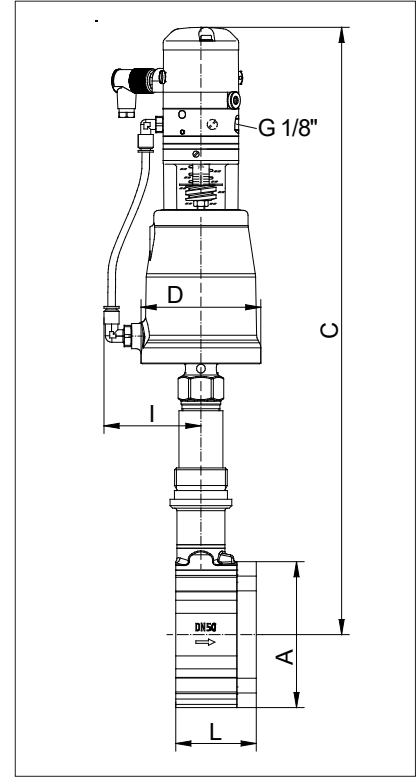

Type 8043 with i/p-positioner  
Type 8047  
with position indicator

DN	Actuator Ø	A	L	D	I	C			Stroke H	Weight (kg)
						p/p positioner	i/p positioner	digital positioner		
15	80	64	56	96	80	426	458	484	6	6,2
15	125	64	56	146	105	446	478	504	6	8
20	80	72	56	96	80	430	462	488	6	6,5
20	125	72	56	146	105	450	482	508	6	8,3
25	80	82	56	96	80	435	467	493	6	6,7
25	125	82	56	146	105	455	487	513	6	8,5
32	80	89	56	96	80	437	469	495	6	6,8
32	125	89	56	146	105	457	489	515	6	8,6
40	80	99	56	96	80	443	475	501	6	7,2
40	125	99	56	146	105	463	495	521	6	9
50	80	116	64	96	80	451	483	509	8	8,7
50	125	116	64	146	105	471	503	529	8	10,5
65	80	138	68	96	80	460	492	518	8	10,2
65	125	138	68	146	105	480	412	538	8	12
80	80	153	70	96	80	469	501	527	8	11,4
80	125	153	70	146	105	489	521	547	8	13,2
100	80	184	75	96	80	482	514	540	8,5	14,7
100	125	184	75	146	105	502	534	560	8,5	16,4
125	80	212	80	96	80	497	529	555	8,5	18,9
125	125	212	80	146	105	517	549	575	8,5	20,6
150	80	242	80	96	80	512	544	570	8,5	22,6
150	125	242	80	146	105	532	564	590	8,5	24,3
200	80	302	93	96	80	-	-	600	8,5	39,5
200	125	302	93	146	105	-	-	620	8,5	41,2
250	80	360	96	96	80	-	-	625	8,5	44,7
250	125	360	96	146	105	-	-	645	8,5	46,4

Dimension C „reduced design“ shortened by 25,4 mm

Dimensions in mm