

GS 3 series, DN 15 up to DN 150

Pneumatic controller for continuous and discontinuous pressure control of gases and steam.

- High dynamic and control quality
- External or manual set point setting
- Compact and simple design of valve as well as of controller
- Lowest possible weight



Technical Information

Valve

Body design	Flangeless, wafer-type construction more versions see on data-sheet 8042-GS1		
Nominal sizes	DN 15 up to DN 150		
Nominal pressure acc. DIN 2401 for flanges with facing type B	PN 40 (fitting for PN 10-25)	DN 15 - DN 150	
Nominal pressure acc. ANSI for flanges acc. ASME B16.5 RF	ANSI 150	DN 15 - DN 150	
	ANSI 300	DN 15 - DN 150	
Nominal pressure acc. JIS for „raised face“ flanges	10K	DN 15 - DN 50	
	20K	DN 15 - DN 40	
Fluid temperature	Versions from -60°C up to +230°C		
Leakage % of Kvs IEC 60534-4 EN 12266-1	Disc pair Carbon-stainless steel	Disc pair SFC	Disc pair STN 2
	< 0,0001	< 0,0005	< 0,001
	IV-S1	IV-S1	IV
	D	E	E
Specific leakage rate shaft and body sealing	ISO FE-BH-CC3-SSA0-t(-40°C/+350°C)-PN40-ISO 15848-1		

Controller

Control pressure ranges	0,05 - 1 bar (remote operation) 0,5 - 6 bar (remote operation) 0,5 - 2,5 bar (manual operation)
Supply pressure	4 - 6 bar
Temperature range for diaphragm system	60 °C, maximum

* With DN15 with reduction of less than 25%, different leakage rates possible.
K_{vs}-values see data sheet 8001.

Fluid temperature

Rating	PN40	PN 16	PN 100	ANSI 150	ANSI 300	ANSI 600
Body material cpl. stainless steel						
Tmin [°C]	-60	-60	-60	-29	-29	-29
Tmax [°C]	230	230	230	230	230	230
Body material cpl. carbon steel						
Tmin [°C]	-60	-60	-10	-20	-20	-10
Tmax [°C]	230	230	230	230	230	230
Body material carbon steel with stainless steel body cover						
Tmin [°C]	-60	-60	-10	-20	-20	-20
Tmax [°C]	230	230	230	230	230	230

Function

The steam or gas pressure from the installation (pressure chamber or pipe) is applied to the controller's diaphragm and compared to the set point signal. As a result of this comparison, supply air is either delivered to the actuator or exhausted. Consequently valve position and flow change, as well as the controlled pressure. The controller can be used for non-continuous processes with varying set points as well as for continuous pressure control (e.g. pressure reduction of steam). Examples can be found at the end of this brochure.

Remark: This proportional controller has a high internal gain and might not replace a conventional control loop with considerable dead times. Practical experience, however, indicates that many different pressure control loops can be handled with this system. To reduce the application risk prior to installation we recommend factory consultation, which is in any case worthwhile due to the potential cost reduction (no pressure gauge and process controller required).

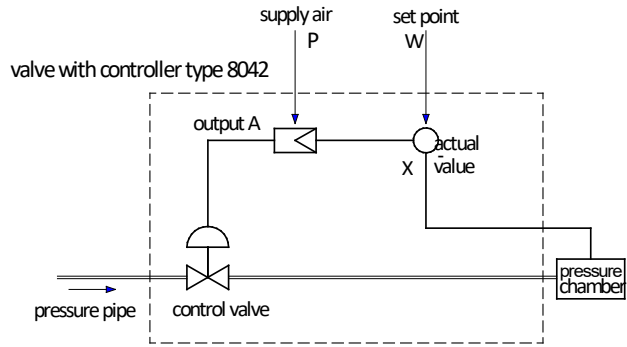

Application Examples

Pressure control in a closed chamber:

The pressure in a steam vessel is to be controlled in accordance with a varying set point signal, which is a current signal determined by the process controller (e.g. a CPS). This signal first is converted to a pressure signal by an i/p-converter and then fed to the pressure controller type 8042. The actual steam pressure is picked up via a pilot line which at the same time takes care of cooling down the medium before it gets into contact with the controller's diaphragm system.

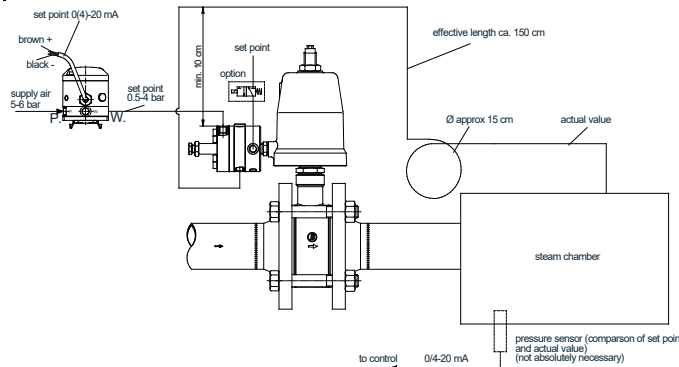

Steam pressure reduction in an energy supply line:

The pressure in a steam supply installation is to be maintained constant in spite of varying flow and upstream pressure. Due to the controller's high dynamic the sketched solution can be used in case of rapidly and strongly changing flows.

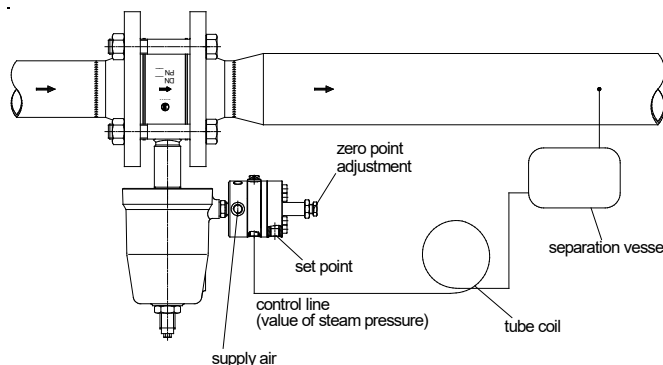

Materials

Valve

Body	stainless steel 1.4581 or 1.4404 /1.4408	carbon steel 1.0619 or 1.0570
Head section	stainless steel 1.4571	carbon steel 1.0570
Bonnet	brass, chrome plated, for actuator 125 mm: aluminium, corrosion protected	
Packing	PTFE, carbon filled	
Actuating stem	stainless steel 1.4571, roller burnished	
Fixed disc	stainless steel covered	STN 2
Sliding disc	special carbon material	SFC
coupling ring for sliding disc	stainless steel 1.4581	

Controller

Body	brass, chrome plated
------	----------------------

Admissible differential pressures
 (For temperatures of up to 120°C with PN-rating
 up to 38°C with ANSI-rating)

**For temperatures of 120°C (PN)
 or 38°C (ANSI) and above:
 obey application limits !**

Disc-pair: Carbon - stainless steel coated

Disc pair: STN 2

DN	actuator	max. differential pressures		P min. (supply)
		control	on/off	
15	80	25	37	5
20	80	22	33	5
25	80	19	28	5
32	80	16	24	5
40	80	14	22	5
50	80	10	16	5
65	80	6	9	5
80	80	4	6	5
100	80	2,5	3,5	5
50	125	24	36	4
65	125	14	21	4
80	125	9	13	4
100	125	6	9	4
125	125	4	6	4
150	125	3	4,5	4

DN	actuator	max. differential pressures		P min. (supply)
		control	on/off	
15	80	17	27	5
20	80	15	24	5
25	80	13	20	5
32	80	11	17	5
40	80	10	16	5
50	80	7	11	5
65	80	4	6	5
80	80	2,5	3,5	5
100	80	1,5	2	5
50	125	16	25	4
65	125	10	15	4
80	125	6	9	4
100	125	3,5	5	4
125	125	-	-	-
150	125	-	-	-

	Upper limits for admissible pressures in bar			
	PN16	PN40	ANSI150	ANSI 300
P max. carbon steel	16	40	19,6	51,1
P max. stainless steel			19,0	49,6

Application limitations for GS3 valves in stainless steel

These pressure must not be exceeded for GS-valves from the GS3-series made of stainless steel, even though the actuator power might allow it.

PN40

DN	Sliding unit: carbon/SFC - stainless steel, coated						Sliding unit: STN2					
	max. admissible pressures for GS3-valves in stainless steel						max. admissible pressures for GS3-valves in stainless steel					
	100°C	150°C	200°C	250°C	300°C	350°C	100°C	150°C	200°C	250°C	300°C	350°C
15-32	40	40	40	40	40	40	40	40	40	40	40	40
40	40	40	40	40	40	40	40	40	40	40	40	37
50	40	40	40	40	40	40	40	40	40	40	40	40
65	40	40	40	40	40	40	40	40	40	40	37	32
80	40	40	40	40	40	40	36	34	33	26	22	19
100	33	33	33	33	33	33	32	31	30	24	20	17
125	23	23	23	23	23	23	21	21	19	16	13	11
150	16	16	16	16	16	16	15	15	14	11	9	8

Limitation for SFC-sliding discs: 300°C

ANSI150

DN	Sliding unit: carbon/SFC - stainless steel, coated								Sliding unit: STN2							
	max. admissible pressures for GS3-valves in stainless steel								max. admissible pressures for GS3-valves in stainless steel							
	38°C	50°C	100°C	150°C	200°C	250°C	300°C	350°C	38°C	50°C	100°C	150°C	200°C	250°C	300°C	350°C
15-125	19,0	18,4	16,2	14,8	13,7	12,1	10,2	8,4	19,0	18,4	16,2	14,8	13,7	12,1	10,2	8,4
150	16,0	16,0	16,0	14,8	13,7	12,1	10,2	8,4	16,2	16,2	16,2	14,8	13,7	11,8	9,7	8,4

Limitation for SFC-sliding discs: 300°C

ANSI300

DN	Sliding unit: carbon/SFC - stainless steel, coated								Sliding unit: STN2							
	max. admissible pressures for GS3-valves in stainless steel								max. admissible pressures for GS3-valves in stainless steel							
	38°C	50°C	100°C	150°C	200°C	250°C	300°C	350°C	38°C	50°C	100°C	150°C	200°C	250°C	300°C	350°C
15-65	49,6	48,1	42,2	38,5	35,7	33,4	31,6	30,3	49,6	48,1	42,2	38,5	35,7	33,4	31,6	30,3
80	48,0	48,0	42,2	38,5	35,7	33,4	31,6	30,3	36,6	36,6	36,6	34,8	33,0	26,8	22,0	19,0
100	33,0	33,0	33,0	33,0	33,0	33,0	31,6	30,3	33,0	33,0	33,0	31,7	30,1	24,4	20,1	17,3
125	23,0	23,0	23,0	23,0	23,0	23,0	23,0	23,0	22,0	22,0	22,0	21,0	19,9	16,1	13,2	11,5
150	16,0	16,0	16,0	16,0	16,0	16,0	16,0	16,0	16,0	16,0	16,0	15,4	14,6	11,8	9,7	8,4

Limitation for SFC-sliding discs: 300°C

Application limitations for GS3 valves in carbon steel

These pressure must not be exceeded for GS-valves from the GS3-series made of carbon steel, even though the actuator power might allow it.

PN40

DN	Sliding unit: carbon/SFC - stainless steel, coated						Sliding unit: STN2					
	max. admissible pressures for GS3-valves in carbon steel						max. admissible pressures for GS3-valves in carbon steel					
	100°C	150°C	200°C	250°C	300°C	350°C	100°C	150°C	200°C	250°C	300°C	350°C
15-50	40	40	40	40	40	40	40	40	40	40	40	40
65	40	40	40	40	40	40	40	40	40	40	37	32
80	40	40	40	40	40	40	36	34	33	26	22	19
100	33	33	33	33	33	33	33	31	30	24	20	17
125	23	23	23	23	23	23	22	21	19	16	13	11
150	16	16	16	16	16	16	16	15	14	11	9	8

Limitation for SFC-sliding discs: 300°C

ANSI150

DN	Sliding unit: carbon/SFC - stainless steel, coated								Sliding unit: STN2							
	max. admissible pressures for GS3-valves in carbon steel								max. admissible pressures for GS3-valves in carbon steel							
	38°C	50°C	100°C	150°C	200°C	250°C	300°C	350°C	38°C	50°C	100°C	150°C	200°C	250°C	300°C	350°C
15-125	19,6	19,2	17,7	15,8	13,8	12,1	10,2	8,4	19,6	19,2	17,7	15,8	13,8	12,1	10,2	8,4
150	16,0	16,0	16,0	15,8	13,8	12,1	10,2	8,4	16,2	16,2	16,2	15,4	13,8	11,8	9,7	8,0

Limitation for SFC-sliding discs: 300°C

ANSI300

DN	Sliding unit: carbon/SFC - stainless steel, coated								Sliding unit: STN2							
	max. admissible pressures for GS3-valves in carbon steel								max. admissible pressures for GS3-valves in carbon steel							
	38°C	50°C	100°C	150°C	200°C	250°C	300°C	350°C	38°C	50°C	100°C	150°C	200°C	250°C	300°C	350°C
15-50	51,1	50,1	46,6	45,1	43,8	41,9	19,8	40,0	51,1	50,1	46,6	45,1	43,8	41,9	19,8	37,6
65	51,1	50,1	46,6	45,1	43,8	41,9	19,8	40,0	41,7	41,7	41,7	39,7	37,6	33,5	19,8	32,5
80	48,0	48,0	46,6	45,1	43,8	41,9	19,8	40,0	36,6	36,6	36,6	34,8	33,0	26,8	19,8	19,0
100	33,0	33,0	33,0	33,0	33,0	33,0	19,8	33,0	33,0	33,0	33,0	31,7	30,1	24,4	19,8	17,0
125	23,0	23,0	23,0	23,0	23,0	23,0	19,8	23,0	22,1	22,1	22,1	21,0	19,9	16,1	13,2	11,0
150	16,0	16,0	16,0	16,0	16,0	16,0	16,0	16,0	16,0	16,0	16,0	15,4	14,6	11,8	9,7	8,0

Limitation for SFC-sliding discs: 300°C

Dimensions and Weights

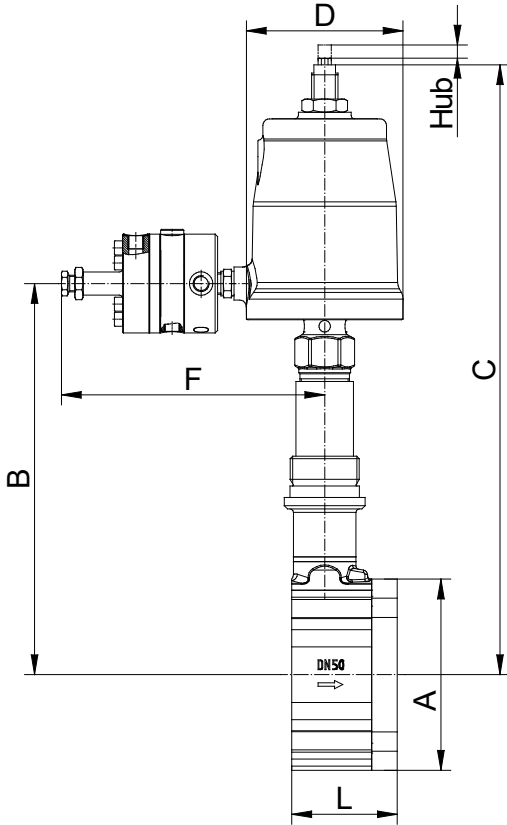

manually operated

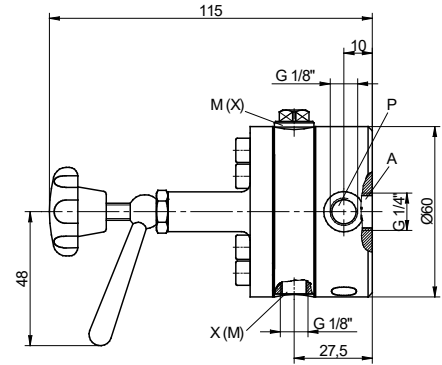

remotely operated

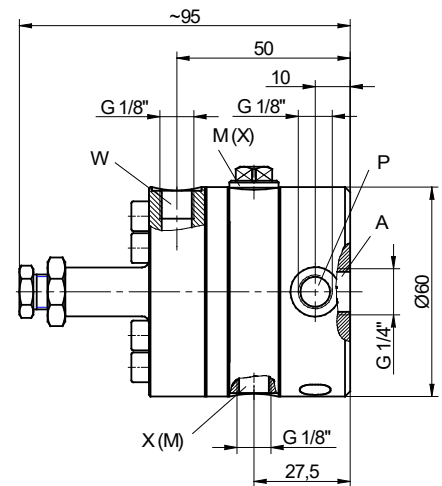

DN	A	B		C max		L	Weight kg		Stroke
		80	125	80	125		80	125	
15	64	213	215	344	362	56	5,9	7,3	6
20	72	217	219	348	366	56	6,1	7,5	6
25	82	222	224	353	371	56	6,4	7,8	6
32	89	224	226	355	373	56	6,6	8	6
40	99	230	232	361	379	56	6,9	8,3	6
50	116	238	240	371	389	64	8,4	9,8	8
65	138	247	249	380	398	68	9,9	11,3	8
80	153	256	258	389	407	70	11,1	12,5	8
100	184	269	271	402	420	75	14,3	15,7	8,5
125	212	283	286	416	434	80	16,6	18	8,5
150	242	296	298	429	447	80	20,4	21,8	8,5

Actuator mm	D	E
80	96	55
125	146	80

Dimensions in mm

Dimension C „reduced design“ shortened by 25,4 mm