

GS 1 series, DN 15 up to DN 150

Pneumatic controller for continuous and discontinuous pressure control of gases and steam.

- High dynamic and control quality
- External or manual set point setting
- Compact and simple design of valve as well as of controller
- Lowest possible weight

Technical Information

Valve

Body design	wafer-type construction, body Dimensions acc. DIN EN 558-1 series 20 for flanges acc. DIN EN 1092-1 form B more versions see data-sheet 8042-GS3		
Nominal sizes	DN 15 up to DN 150		
Nominal pressure (acc. DIN 2401)	PN 40 (fitting for PN 10-40)		
Fluid temperature	-10°C up to +230°C		
Leakage *	Disc pair Carbon-stainless steel	Disc pair SFC	Disc pair STN 2
% of Kvs	< 0,0001	< 0,0005	< 0,001
IEC 60534-4	IV-S1	IV-S1	IV
EN 12266-1	D	E	E
Packing leakage	tested according to TA-Luft as defined in DIN EN ISO 15848-1 and VDI 2440		

Controller

Control pressure ranges	0,05 - 1 bar (remote operation) 0,5 - 6 bar (remote operation) 0,5 - 2,5 bar (manual operation)
Supply pressure	4 - 6 bar
Temperature range for diaphragm system	60 °C, maximum

* With DN15 with reduction of less than 25%, different leakage rates possible.
K_{vs}-values see data sheet 8001.

Materials

Valve

Body	stainless steel 1.4581 or 1.4404 /1.4408	carbon steel 1.0619 or 1.0570
Bonnet	brass, chrome plated, for actuator 125 mm: aluminium, corrosion protected	
Packing	PTFE, carbon filled	
Actuating stem	stainless steel 1.4571, roller burnished	
Fixed disc	stainless steel covered	STN 2
Sliding disc	special carbon material	SFC
coupling ring for sliding disc	stainless steel 1.4581	STN 2

Controller

Body	brass, chrome plated	
------	----------------------	--



Connections:

- P supply air
- X actual value (pressure to be controlled)
- M pressure gauge (if required)
- W air supply valve
- A exit to valve actuator

Function

The steam or gas pressure from the installation (pressure chamber or pipe) is applied to the controller's diaphragm and compared to the set point signal. As a result of this comparison, supply air is either delivered to the actuator or exhausted. Consequently valve position and flow change, as well as the controlled pressure. The controller can be used for non-continuous processes with varying set points as well as for continuous pressure control (e.g. pressure reduction of steam). Examples can be found at the end of this brochure.

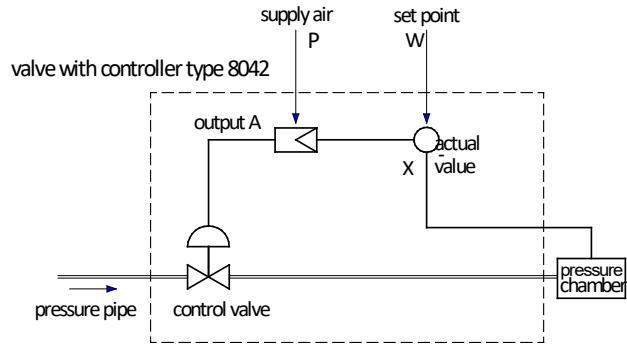

Remark: This proportional controller has a high internal gain and might not replace a conventional control loop with considerable dead times. Practical experience, however, indicates that many different pressure control loops can be handled with this system. To reduce the application risk prior to installation we recommend factory consultation, which is in any case worthwhile due to the potential cost reduction (no pressure gauge and process controller required).

Application Examples

Pressure control in a closed chamber:

The pressure in a steam vessel is to be controlled in accordance with a varying set point signal, which is a current signal determined by the process controller (e.g. a CPS). This signal first is converted to a pressure signal by an i/p-converter and then fed to the pressure controller type 8042. The actual steam pressure is picked up via a pilot line which at the same time takes care of cooling down the medium before it gets into contact with the controller's diaphragm system.

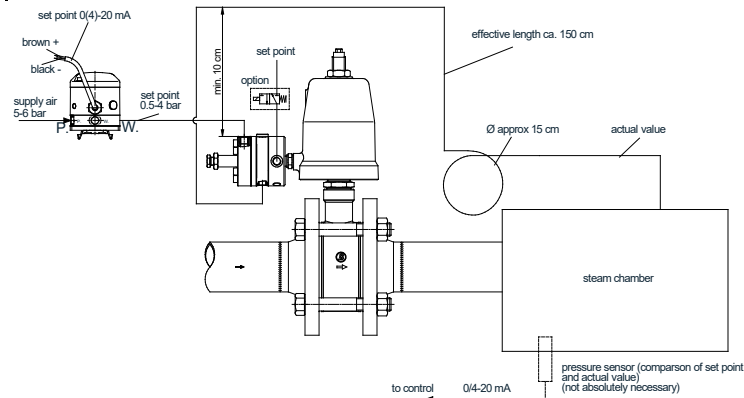

Steam pressure reduction in an energy supply line:

The pressure in a steam supply installation is to be maintained constant in spite of varying flow and upstream pressure. Due to the controller's high dynamic the sketched solution can be used in case of rapidly and strongly changing flows.

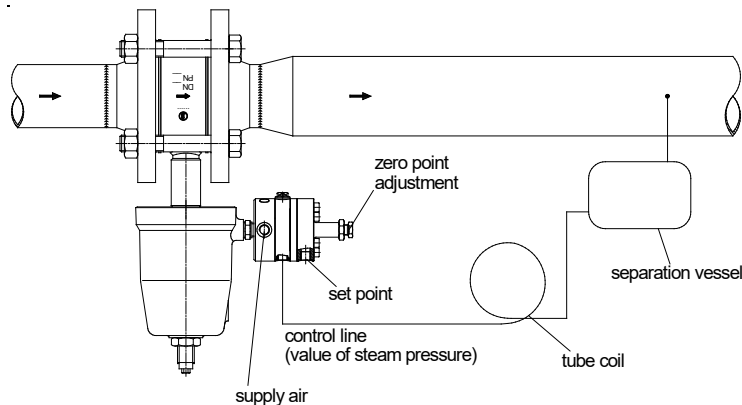

Admissible Differential Pressure (For temperatures of up to 120°C)

**For temperatures of 120°C and above:
obey application limits !**

Disc-pair: Carbon - stainless steel coated SFC - stainless steel coated

DN	actuator	max. differential pressure		Pst min.
		control	on/off	
15	80	25	37	5
20	80	22	33	5
25	80	19	28	5
32	80	16	24	5
40	80	14	22	5
50	80	10	16	5
65	80	6	9	5
80	80	4	6	5
100	80	2,5	3,5	5
50	125	24	36	4
65	125	14	21	4
80	125	9	13	4
100	125	6	9	4
125	125	4	6	4
150	125	3	4,5	4

Disc pair: STN 2

DN	actuator	max. differential pressure		Pst min.
		control	on/off	
15	80	17	27	5
20	80	15	24	5
25	80	13	20	5
32	80	11	17	5
40	80	10	16	5
50	80	7	11	5
65	80	4	6	5
80	80	2,5	3,5	5
100	80	1,5	2	5
50	125	16	25	4
65	125	10	15	4
80	125	6	9	4
100	125	3,5	5	4
125	125	-	-	-
150	125	-	-	-

Applications limits for GS1-Valves

PN 40

DN	Couple glissières: carbone/SFC - inox			
	Pression max en bar pour vannes GS1			
	100°C	150°C	200°C	230°C
15 - 25	40	36	31	30
32	40	36	31	30
40	40	36	31	30
50	40	36	31	30
65	40	36	31	30
80	40	36	31	30
100	24	23	22	20
125	16	15	14	13
150	16	16	16	16

DN	Couple glissières: STN 2			
	Pression max en bar pour vannes GS3 en inox			
	100°C	150°C	200°C	230°C
40	36	36	31	30
40	36	36	31	24
26	25	24	24	15
40	36	36	31	26
37	35	35	31	21
22	20	20	19	12
13	12	12	12	7
8	8	8	7	4
10	10	10	9	6

Dimensions and Weights

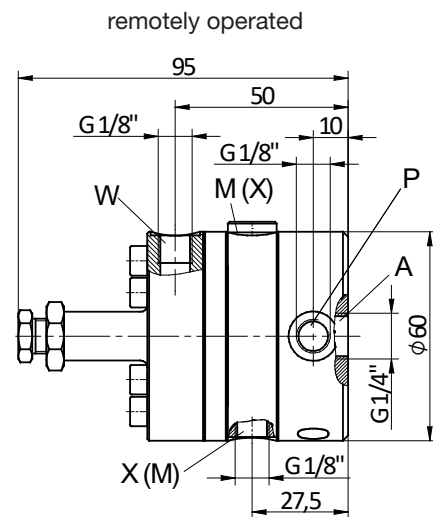
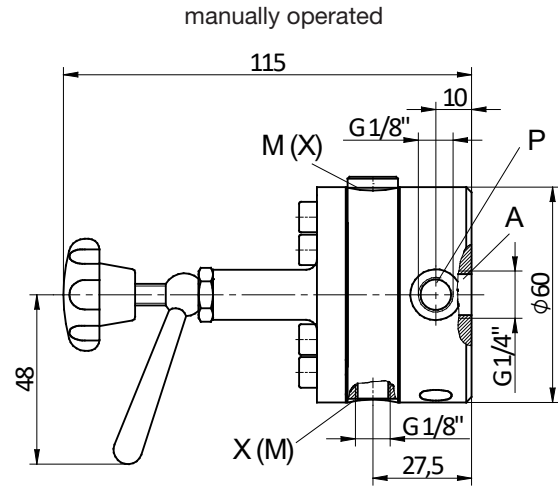
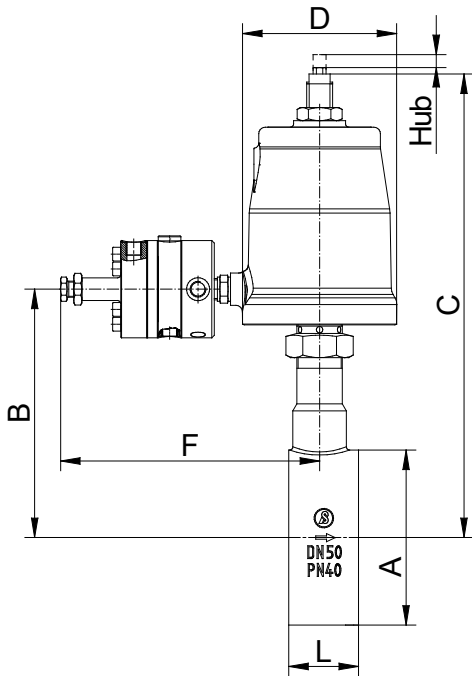

DN	A	B		B		C		C		D		F		L	Stroke
		Stainless Steel	Carbon Steel	Stainless Steel	Carbon Steel	Stainless Steel	Carbon Steel	D80	D125	D80	D125	D80	D125		
15	53	112	115	135	138	243	285	266	285	98	146	160	185	33	6
20	62	117	120	140	143	248	290	271	290	98	146	160	185	33	6
25	72	122	125	145	148	253	295	276	295	98	146	160	185	33	6
32	82	126	129	148	151	257	298	279	298	98	146	160	185	33	6
40	92	131	134	153	156	3262	303	284	303	98	146	160	185	33	6
50	108	154	157	154	157	287	306	287	306	98	146	160	185	43	8
65	126	163	166	163	166	296	315	296	315	98	146	160	185	46	8
80	142	171	174	171	174	304	323	304	323	98	146	160	185	46	8
100	164	184	187	184	187	317	336	317	336	98	146	160	185	52	8,5
125	194	196	199	196	200	329	349	329	349	98	146	160	185	56	8,5
150	219	217	220	217	221	350	369	350	370	98	146	160	185	56	8,5

Dimension C „reduced design“ shortened by 25,4 mm

Dimensions in mm