

# Motor Valve 8037

ex-version

GS 3 series, DN 15 up to DN 250

Motor valve for control and switching of neutral through to highly aggressive media in process engineering, chemical industries and for plant equipment, for applications in Ex-Zone 1, 2, 21 and 22.



## Technical Information Valve

Design	Flangeless design for flanges acc. EN 1092-1 form B or ASME B16.5 RF further versions see data sheet 8037-GS3		
Nominal size	DN 15 up to DN 250		
Nominal pressure acc. DN 1333	PN 40 (fits also to PN 10-25)	DN 15 - DN 150	
	PN 100	DN 15 - DN 80	
	PN 16	DN 200 - DN 250	
Nominal pressure acc. ANSI	ANSI 150	DN15 - DN 250	
	ANSI 300	DN 15 - DN 150	
	ANSI 600	DN 15 - DN 80	
Nominal pressure acc. JIS for raised face flanges	10K	DN 15 - DN 50	
	20K	DN 15 - DN 40	
Media temperature	Versions from -60°C up to +350°C		
Rangeability	30 : 1		
Leakage (% of Kvs)	Disc pair Carbon-stainless steel	Disc pair SFC	Disc pair STN 2
	< 0,0001	< 0,0005	< 0,001
	Specific leakage rate shaft and body sealing		
	ISO FE-BH-CC3-SSA0-t(-40°C/+350°C)-PN40-ISO 15848-1		

\* With DN15 with reduction of less than 25%, different leakage rates possible.  
K<sub>vs</sub>-values see data sheet 8001.

## Technical Information Actuator

Driving force	1 kN , 2,5 kN , 5 kN
Stroking speed	2 / 3 / 6 / 9 / 12 s/mm (adjustable)
Power supply	24 ... 230 V AC/DC (longer range power supply )
Input signal	3-point 4 - 20 mA or 0 - 10 V
Feedback	4 - 20 mA or 0 - 10 V
Explosion protection (gas)	II 2G Ex de [ia] IIC T6/T5
Explosion protection (dust)	II 2D Ex tD [iaD] A21 IP66 T80°C
Protection class	IP 66
Ambient temperature	-20...+40°C at T6 / -20...+50°C at T5
Operating mode	S3 / 50% ED (max. 600 switching cycle / h)
Hysteresis	ca. ±1,5%
Resolution	ca. 100 steps
Ambient temperature	self-learning
Heating resistor element	16 Watt self actuating
Motor	brushless DC motor
Manual override	hexagon key (top of header)

## Fluid temperature

Rating	PN40	PN 16	PN 100	ANSI 150	ANSI 300	ANSI 600
Body material cpl. stainless steel						
Tmin [°C]	-60	-60	-60	-29	-29	-29
Tmax [°C]	350	350	350	350	350	350
Body material carbon steel with stainless steel body cover						
Tmin [°C]	-60	-60	-10	-20	-20	-20
Tmax [°C]	350	350	350	350	350	350

## ex-version

### Materials

Body	stainless steel 1.4408	carbon steel 1.0619	
Bodycover	stainless steel 1.4404 or 316L	carbon steel 1.0570	
Bonnet	brass plated (actuator ø 50 mm, ø 80 mm) aluminium corrosion proof (actuator ø 125 mm)		
Springs	stainless steel 1.4301 (actuator ø 50 mm, ø 80 mm) spring steel wire C, coated (actuator ø 125 mm)		
Packing	PTFE carbon filled (spring 1.4310)		
Valve stem	stainless steel 1.4571, roller burnished		
Bellow	stainless steel 1.4571		
Fixed plate	stainless steel 1.4571, plated	STN2-disc	
Sliding disc	standard: special carbon material	SFC-disc	STN2-disc
Coupling ring for disc	stainless steel 1.4581		

### Stroking times for the complete stroke (sec.):

Speed [s/mm]	2	3	6	9	12
DN 15 - 40	12,5	18,8	37,5	56,3	75,0
DN 50 - 80	16,5	24,8	49,5	74,3	99,0
DN 100 - 250	17,5	26,3	52,5	78,8	105,0

= factory setting

### Admissible differential pressures (For temperatures of up to 120°C with PN-rating up to 38°C with ANSI-rating)

**For temperatures of 120°C (PN)  
or 38°C (ANSI) and above:  
obey application limits !**

DN	1,0 kN	2,5 kN	5,0 kN	1,0 kN	2,5 kN	5,0 kN
	max. differential pressure (bar)			max. differential pressure (bar)		
	carbon/SFC - stainless steel coated			STN2		
15	88,3	102,1	102,1	62,7	102,1	102,1
20	76,7	102,1	102,1	48,3	102,1	102,1
25	64,2	88 (102,1)*	88 (102,1)*	36,1	88 (96,2)*	88 (102,1)*
32	52,6	102,1	102,1	26,8	71,5	102,1
40	39,8	88 (100)*	88 (100)*	18,4	49,1	72,6
50	26,1	69,6	100	11	29,3	59,9
65	22	58,6	80	9	24	49,1
80	14	37,2	48	5,5	14,5	29,7
100	8,9	23,8	33	3,4	9	18,4
125	6,1	16,2	23	2,3	6	12,3
150	4,5	12,1	16	1,7	4,5	9,1
200	2,6	7	14,3	-	-	-
250	1,6	4,3	8,8	-	-	-

\*: figures in brackets for bodies made of carbon steel

	Upper limits for admissible pressures in bar					
	PN16	PN40	PN100	ANSI150	ANSI 300	ANSI 600
P max. carbon steel	16	40	100	19,6	51,1	102,1
P max. stainless steel				19,0	49,6	99,3

### Options

- 2 potential-free limit switches at a separated terminal box
- inductive proximity switches (mounted at the column)
- Version only for zone 2 and zone 22
- Version not ex-actuator

## ex-version

### Ordering Number System

Pos. 1 up to 4 please quote.

Pos. 5 up to 13 quote only if required.

From pos. 14 if required, quoted by the manufacturer.

Ordering Number:		1	2	3	4	5	6	7	8	9	10	11	12	13	14
8037/				H			M							Z	...
<b>Nominal Size</b>															
e.g. DN 25 = 025			xxx												
<b>Article</b>															
valve				V											
lower part				U											
repair-kit				R											
<b>Function</b>															
ex-proofed motor actuator (Type 8037)				H											
<b>Body design</b>															
GS3 - flangeless design acc. DIN, PN10 - PN40, (DN200 PN16)					G										
GS3 - flangeless design acc. DIN, PN100					H										
GS3 - flangeless design, acc. ANSI 150					E										
GS3 - flangeless design, acc. ANSI 300					F										
<b>Body material</b>															
C-steel 1.0570 alternatively 1.0619					0										
stainless steel 1.4581/1.4571 or 1.4408/1.4404					1										
<b>Safety position</b>															
without safety position					0										
<b>Motor actuator</b>															
without actuator						0									
1 kN driving force, on /off, 3-point, IP66, 24...230V AC/DC, II 2GEx de [ia] IIC T5/T6						1									
2,5 kN driving force, on /off, 3-point, IP66, 24...230V AC/DC, II 2GEx de [ia] IIC T5/T6						2									
5 kN driving force, on /off, 3-point, IP66, 24...230V AC/DC, II 2GEx de [ia] IIC T5/T6						3									
1 kN driving force with electronic positioner, IP66, 24...230V AC/DC, control signal, 4-20mA/0-10V, feed-back 4-20 mA/0-10V, II2G Ex de [ia] IIC T5/T6							A								
2,5 kN driving force with electronic positioner, IP66, 24...230V AC/DC, control signal 4-20mA/0-10V, feed-back 4-20 mA/0-10V, II2G Ex de [ia] IIC T5/T6							B								
5 kN driving force with electronic positioner, IP66, 24...230V AC/DC, control signal 4-20mA/0-10V, feed-back 4-20 mA/0-10V, II2G Ex de [ia] IIC T5/T6							C								
<b>Motor voltage</b>															
24...230V AC/DC (standard)							-								
<b>Stem sealing</b>															
standard ( PTFE-V-shaped seal, self-adjusting)								-							
additional stainless steel bellows									1						
<b>Sliding disc</b>															
carbon steel										-					
STN2/STN3										9					
SFC										S					
<b>Fixed disc</b>															
standard coated, stainless steel 1.4571											-				
STN2											1				
STN3											2				
<b>Kvs-value</b>															
100% (standard)												-			
red. 63%													A		
red. 40%														1	
red. 25%															B
red. 16%															2
red. 10%															C
further reductions on request (see data sheet 8001)															...
<b>Seat characteristics</b>															
linear														-	
equal percentage															1
<b>Accessories</b>															
please note if required															Z

pos. 1 up to 4 please quote

pos. 5 up to 13 quote only if required.

from pos. 14 if required, quoted by the manufacturer

**On request further versions are possible!**

### Application limitations for GS3 valves in stainless steel

These pressure must not be exceeded for GS-valves from the GS3-series made of stainless steel, even though the actuator power might allow it.

#### PN40

DN	Sliding unit: carbon/SFC - stainless steel, coated						Sliding unit: STN2					
	max. admissible pressures for GS3-valves in stainless steel						max. admissible pressures for GS3-valves in stainless steel					
	100°C	150°C	200°C	250°C	300°C	350°C	100°C	150°C	200°C	250°C	300°C	350°C
15-32	40	40	40	40	40	40	40	40	40	40	40	40
40	40	40	40	40	40	40	40	40	40	40	40	37
50	40	40	40	40	40	40	40	40	40	40	40	40
65	40	40	40	40	40	40	40	40	40	40	37	32
80	40	40	40	40	40	40	36	34	33	26	22	19
100	33	33	33	33	33	33	32	31	30	24	20	17
125	23	23	23	23	23	23	21	21	19	16	13	11
150	16	16	16	16	16	16	15	15	14	11	9	8
200 (only PN16)	16	16	15	13	12	11	-	-	-	-	-	-
250 (only PN16)	10	9	9	8	7	6	-	-	-	-	-	-

Limitation for SFC-sliding discs: 300°C

#### PN100

DN	Sliding unit: carbon/SFC - stainless steel, coated						Sliding unit: STN2					
	max. admissible pressures for GS3-valves in stainless steel						max. admissible pressures for GS3-valves in stainless steel					
	100°C	150°C	200°C	250°C	300°C	350°C	100°C	150°C	200°C	250°C	300°C	350°C
15	100	100	100	93	84	79	100	100	100	93	84	79
20	100	100	89	81	73	68	100	100	89	81	73	68
25	88	81	70	63	57	54	88	81	70	63	57	54
32	100	93	80	73	65	62	100	93	80	73	65	60
40	88	81	70	63	57	54	72	69	65	53	43	37
50	100	100	100	100	100	94	77	73	70	56	46	40
65	80	80	80	79	71	67	62	59	56	45	37	32
80	48	48	48	48	48	44	36	34	33	26	22	19

Limitation for SFC-sliding discs: 300°C

#### ANSI150

DN	Sliding unit: carbon/SFC - stainless steel, coated								Sliding unit: STN2							
	max. admissible pressures for GS3-valves in stainless steel								max. admissible pressures for GS3-valves in stainless steel							
	38°C	50°C	100°C	150°C	200°C	250°C	300°C	350°C	38°C	50°C	100°C	150°C	200°C	250°C	300°C	350°C
15-125	19,0	18,4	16,2	14,8	13,7	12,1	10,2	8,4	19,0	18,4	16,2	14,8	13,7	12,1	10,2	8,4
150	16,0	16,0	16,0	14,8	13,7	12,1	10,2	8,4	16,2	16,2	16,2	14,8	13,7	11,8	9,7	8,4
200	16,0	16,0	16,0	14,8	13,7	12,1	10,2	8,4	-	-	-	-	-	-	-	-
250	10,4	10,4	10,4	9,9	9,4	8,4	7,4	6,8	-	-	-	-	-	-	-	-

Limitation for SFC-sliding discs: 300°C

#### ANSI300

DN	Sliding unit: carbon/SFC - stainless steel, coated								Sliding unit: STN2							
	max. admissible pressures for GS3-valves in stainless steel								max. admissible pressures for GS3-valves in stainless steel							
	38°C	50°C	100°C	150°C	200°C	250°C	300°C	350°C	38°C	50°C	100°C	150°C	200°C	250°C	300°C	350°C
15-65	49,6	48,1	42,2	38,5	35,7	33,4	31,6	30,3	49,6	48,1	42,2	38,5	35,7	33,4	31,6	30,3
80	48,0	48,0	42,2	38,5	35,7	33,4	31,6	30,3	36,6	36,6	36,6	34,8	33,0	26,8	22,0	19,0
100	33,0	33,0	33,0	33,0	33,0	33,0	31,6	30,3	33,0	33,0	33,0	31,7	30,1	24,4	20,1	17,3
125	23,0	23,0	23,0	23,0	23,0	23,0	23,0	23,0	22,0	22,0	22,0	21,0	19,9	16,1	13,2	11,5
150	16,0	16,0	16,0	16,0	16,0	16,0	16,0	16,0	16,0	16,0	16,0	15,4	14,6	11,8	9,7	8,4

Limitation for SFC-sliding discs: 300°C

#### ANSI600

DN	Sliding unit: carbon/SFC - stainless steel, coated								Sliding unit: STN2							
	max. admissible pressures for GS3-valves in stainless steel								max. admissible pressures for GS3-valves in stainless steel							
	38°C	50°C	100°C	150°C	200°C	250°C	300°C	350°C	38°C	50°C	100°C	150°C	200°C	250°C	300°C	350°C
15-20	99,3	96,2	84,4	77,0	71,3	66,8	63,2	60,7	99,3	96,2	84,4	77,0	71,3	66,8	63,2	60,7
25	88,0	88,0	84,4	77,0	70,1	63,7	57,3	54,2	88,0	88,0	84,4	77,0	70,1	63,7	57,3	54,2
32	99,3	96,2	84,4	77,0	71,3	66,8	63,2	60,7	99,3	96,2	84,4	77,0	71,3	66,8	63,2	60,7
40	88,0	88,0	84,4	77,0	70,1	63,7	57,3	54,2	72,5	72,5	72,5	69,0	65,5	53,1	43,6	37,7
50	99,3	96,2	84,4	77,0	71,3	66,8	63,2	60,7	77,7	77,7	77,7	73,9	70,2	56,9	46,7	40,4
65	80,0	80,0	80,0	77,0	71,3	66,8	63,2	60,7	62,5	62,5	41,7	59,5	56,4	45,8	37,6	32,5
80	48,0	48,0	48,0	48,0	48,0	48,0	48,0	44,5	36,6	36,6	36,6	34,8	33,0	26,8	22,0	19,0

Limitation for SFC-sliding discs: 300°C

### Application limitations for GS3 valves in carbon steel

These pressure must not be exceeded for GS-valves from the GS3-series made of carbon steel, even though the actuator power might allow it.

#### PN40

DN	Sliding unit: carbon/SFC - stainless steel, coated						Sliding unit: STN2					
	max. admissible pressures for GS3-valves in carbon steel						max. admissible pressures for GS3-valves in carbon steel					
	100°C	150°C	200°C	250°C	300°C	350°C	100°C	150°C	200°C	250°C	300°C	350°C
15-50	40	40	40	40	40	40	40	40	40	40	40	40
65	40	40	40	40	40	40	40	40	40	37	32	
80	40	40	40	40	40	40	36	34	33	26	22	19
100	33	33	33	33	33	33	33	31	30	24	20	17
125	23	23	23	23	23	23	22	21	19	16	13	11
150	16	16	16	16	16	16	16	15	14	11	9	8
200 (nur PN 16)	16	16	15	13	12	11	-	-	-	-	-	-
250 (nur PN 16)	10	9	9	8	7	6	-	-	-	-	-	-

Limitation for SFC-sliding discs: 300°C

#### PN100

DN	Sliding unit: carbon/SFC - stainless steel, coated						Sliding unit: STN2					
	max. admissible pressures for GS3-valves in carbon steel						max. admissible pressures for GS3-valves in carbon steel					
	100°C	150°C	200°C	250°C	300°C	350°C	100°C	150°C	200°C	250°C	300°C	350°C
15 - 20	100	100	100	100	100	100	100	100	100	100	100	100
25	100	100	100	100	100	94	100	100	100	94	87	
32	100	100	100	100	100	100	100	100	100	84	69	60
40	100	100	100	100	100	94	72	69	65	53	43	37
50	100	100	100	100	100	94	77	73	70	56	46	40
65	80	80	80	80	80	76	62	59	56	45	37	32
80	48	48	48	48	48	44	36	34	33	26	22	19

Limitation for SFC-sliding discs: 300°C

#### ANSI150

DN	Sliding unit: carbon/SFC - stainless steel, coated								Sliding unit: STN2							
	max. admissible pressures for GS3-valves in carbon steel								max. admissible pressures for GS3-valves in carbon steel							
	38°C	50°C	100°C	150°C	200°C	250°C	300°C	350°C	38°C	50°C	100°C	150°C	200°C	250°C	300°C	350°C
15-125	19,6	19,2	17,7	15,8	13,8	12,1	10,2	8,4	19,6	19,2	17,7	15,8	13,8	12,1	10,2	8,4
150	16,0	16,0	16,0	15,8	13,8	12,1	10,2	8,4	16,2	16,2	16,2	15,4	13,8	11,8	9,7	8,0
200	16,0	16,0	16,0	15,8	13,8	12,1	10,2	8,4	-	-	-	-	-	-	-	-
250	10,5	10,5	10,5	9,9	9,4	8,4	7,4	6,0	-	-	-	-	-	-	-	-

Limitation for SFC-sliding discs: 300°C

#### ANSI300

DN	Sliding unit: carbon/SFC - stainless steel, coated								Sliding unit: STN2							
	max. admissible pressures for GS3-valves in carbon steel								max. admissible pressures for GS3-valves in carbon steel							
	38°C	50°C	100°C	150°C	200°C	250°C	300°C	350°C	38°C	50°C	100°C	150°C	200°C	250°C	300°C	350°C
15-50	51,1	50,1	46,6	45,1	43,8	41,9	19,8	40,0	51,1	50,1	46,6	45,1	43,8	41,9	39,8	37,6
65	51,1	50,1	46,6	45,1	43,8	41,9	19,8	40,0	41,7	41,7	41,7	39,7	37,6	33,5	37,6	32,5
80	48,0	48,0	46,6	45,1	43,8	41,9	19,8	40,0	36,6	36,6	36,6	34,8	33,0	26,8	22,0	19,0
100	33,0	33,0	33,0	33,0	33,0	33,0	19,8	33,0	33,0	33,0	33,0	31,7	30,1	24,4	20,0	17,0
125	23,0	23,0	23,0	23,0	23,0	23,0	19,8	23,0	22,1	22,1	22,1	21,0	19,9	16,1	13,2	11,0
150	16,0	16,0	16,0	16,0	16,0	16,0	16,0	16,0	16,0	16,0	16,0	15,4	14,6	11,8	9,7	8,0

Limitation for SFC-sliding discs: 300°C

#### ANSI600

DN	Sliding unit: carbon/SFC - stainless steel, coated								Sliding unit: STN2							
	max. admissible pressures for GS3-valves in carbon steel								max. admissible pressures for GS3-valves in carbon steel							
	38°C	50°C	100°C	150°C	200°C	250°C	300°C	350°C	38°C	50°C	100°C	150°C	200°C	250°C	300°C	350°C
15-25	102,1	100,2	93,2	90,2	87,6	83,9	79,6	75,1	102,1	100,2	93,2	90,2	87,6	83,9	79,6	75,1
32	102,1	100,2	93,2	90,2	87,6	83,9	79,6	75,1	102,1	100,2	93,2	90,2	87,6	83,9	69,6	60,0
40	100,0	100,0	93,2	90,2	87,6	83,9	79,6	75,1	72,5	72,5	72,5	69,0	65,5	53,1	43,6	37,0
50	100,0	100,0	93,2	90,2	87,6	83,9	79,6	75,1	77,7	77,7	77,7	73,9	70,2	56,9	46,7	40,0
65	80,0	80,0	80,0	80,0	80,0	80,0	79,6	75,1	62,5	62,5	62,5	59,5	56,4	45,8	37,6	32,0
80	48,0	48,0	48,0	48,0	48,0	48,0	48,0	44,0	36,6	36,6	36,6	36,8	33,0	26,8	22,0	19,0

Limitation for SFC-sliding discs: 300°C

# Motor Valve 8037-GS3

ex-version

## Dimensions and Weights

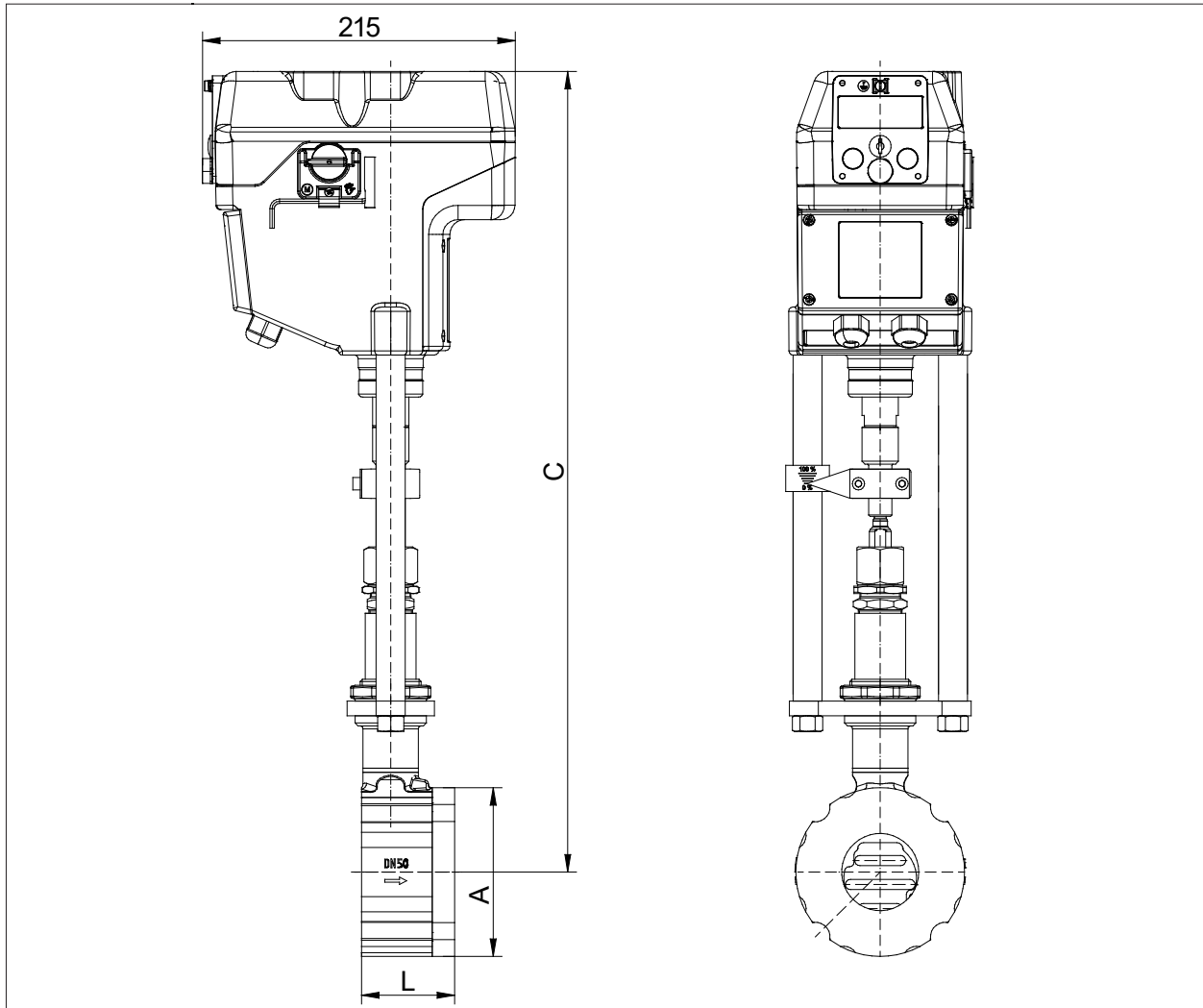

DN	A	C	L	Weight (kg)	Stroke
15	64	520	56	11,2	6
20	72	525	56	11,4	6
25	82	530	56	11,8	6
32	89	535	56	12,2	6
40	99	540	56	12,6	6
50	116	550	64	14,2	8
65	138	560	68	16,0	8
80	153	570	70	17,1	8
100	184	580	75	20,6	8,5
125	212	595	80	24,8	8,5
150	242	610	80	28,5	8,5
200	302	640	93	45,4	8,5
250	360	662	96	50,6	8,5

Dimensions in mm