



Pressure regulating valve

Size 2

637.35 A to 637.35 D
637.523 A to 637.523 D
G 1/2

0.5 to 3 bar
0.5 to 6 bar
0.5 to 10 bar
0.5 to 16 bar

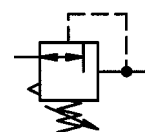

Characteristics

Order No.	637.35 A	637.35 B	637.35 C	637.35 D
	637.523 A	637.523 B	637.523 C	637.523 D
Port	G 1/2			
Pressure gauge port	G 1/4			
Type of construction	Diaphragm pressure regulator with self-relieving design Special versions on request e.g. - Reverse flow port closed			
Max. input pressure p_1	25 bar			
Control range p_2	0.5 to 3 bar / 0.5 to 6 bar / 0.5 to 10 bar / 0.5 to 16 bar			
Mounting position	Any / note direction of arrow			
Mounting type	Panel mounting, hole $\varnothing 20.5$ Bracket			
Medium temperature	-10 to 60°C			
Ambient temp.	-10 to 80°C			
Weight [g]	1100 / 1200 with pressure gauge			

Description

- Standard design
- Double nipples (G 1/2) required for block mounting with other devices
- Pressure setting by means of adjusting screw with plastic knob, setting can be locked with lock nut
- Flow direction indicated by arrows
- **Entry in direction of arrow**
- Virtually independent of inlet pressure
- Pressure gauge $\varnothing 63$ included, can be mounted at both ends
- Panel mounting with nut and washer on cover
- Wall mounting with mounting bracket on cover

Materials

Part	Material
Head piece (body)	Zinc - Z 410
Spring bonnet/adjusting screw	Zinc - Z 410/brass
Diaphragm →	NBR-brass
Pressure spring	Galvanised steel
Valve cone →	NBR-brass
Counter-pressure spring	Stainless steel
O-ring 28 x 2 →	NBR

Accessories

Designation	Order No.
Nut M 20 x 1.5 and washer	74/1
Mounting bracket with nut and washer	75/2
Double nipple G 1/2	252.66
Double nipple R 1/2 (conical) for block mounting with other devices	252.303-N

Main spare parts

Part	Part No.
→ Set of wearing parts - Diaphragm, compl. - Valve cone, compl. - O-ring 28 x 2	22.635.4
Pr. gauge $\varnothing 63$, G1/4 0 to 4 bar	215-KD
0 to 6 bar	216-KD
0 to 10 bar	217-KD
0 to 16 bar	218-KD

Dimensions [mm]

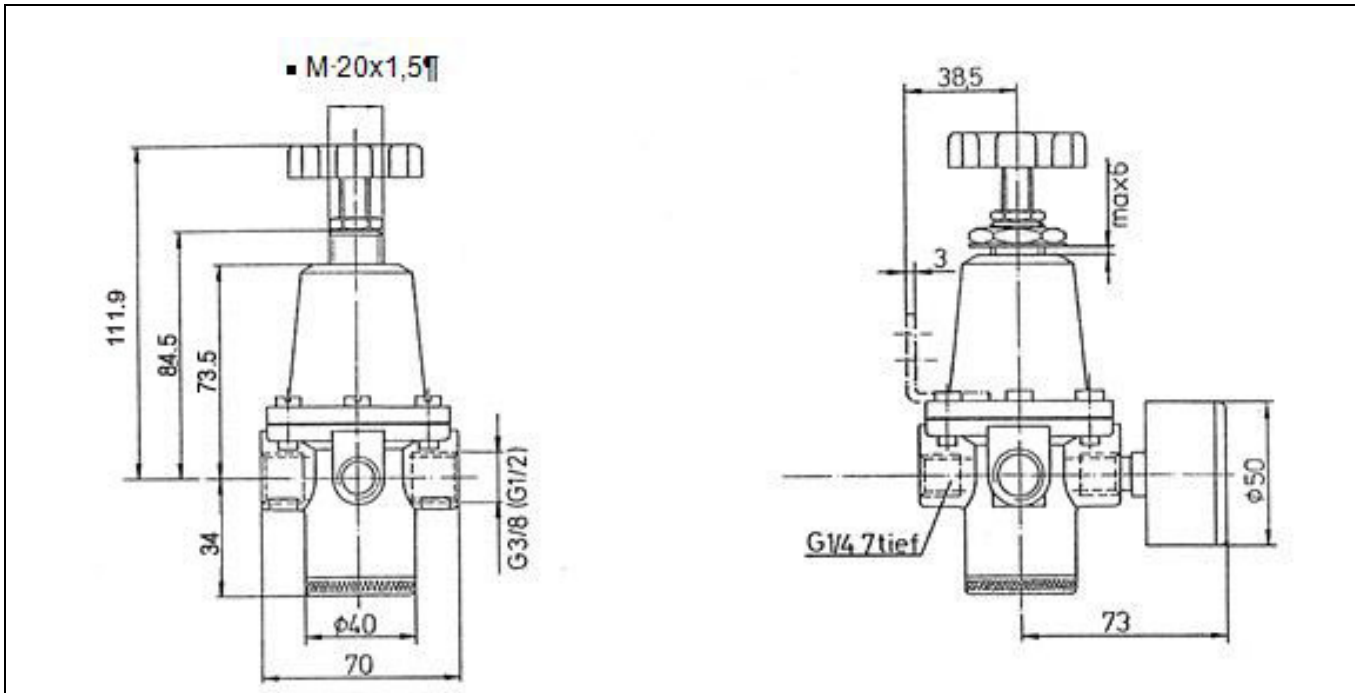

Flow rates

Flow rates at $p_1 = 8 \text{ bar}$

Art. No.		637.35 A	637.35 B	637.35 C	637.35 D
		637.523 A	637.523 B	637.523 C	637.523 D
Output pressure $p_2 = 6 \text{ [bar]}$	QN m^3/h	132	132	132	132
Nominal flow ($\Delta p = 1 \text{ bar}$)	QN l/min	2200	2200	2200	2200

Hysteresis

Hysteresis of p_2 as a function of rising (falling) p_1 at a constant draw-off rate QN 20 l/min
 Basic setting (starting point): $p_1: 7,0 \text{ bar}$
 $p_2: 2.0 \text{ bar}$

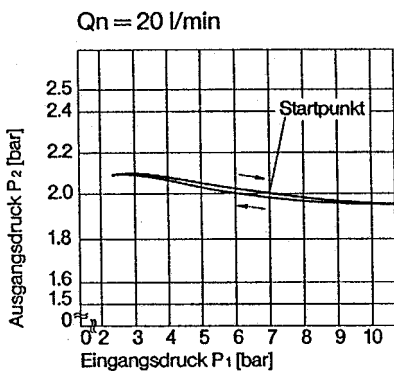

Flow characteristic

Control range 0.5 to 10 bar

