

GS 3 series - DN 15 up to DN 250

Pneumatic control valve for the control of neutral through to highly aggressive media in process engineering, chemical industries and for plant equipment.

- Space-saving wafer-type design
- Lowest possible weight
- Quiet operation
- Fast response
- Control of high differential pressures with small actuators
- Greatly reduced energy consumption rates due to short strokes and low actuating forces on the throttle element
- High Kvs-values



Technical Information

Design	wafer-type design		
Nominal sizes	DN 15 up to DN 250		
Nominal pressure acc. DIN for flanges with facing type B	PN 40 (fits also to PN 10-25) PN 100 PN 16	DN 15 - DN 150 DN 15 - DN 80 DN 200 - DN 250	
Nominal pressure acc. ANSI for flanges acc. ASME B16.5 RF	ANSI 150 ANSI 300 ANSI 600	DN15 - DN 250 DN 15 - DN 150 DN 15 - DN 80	
Nominal pressure acc. JIS for „raised face“ flanges	10K 20K	DN 15 -DN 50 DN 15 -DN 40	
Supply pressure	max. 6 bar		
Fluid temperature	-60°C up to +450°C for function unit carbon-stainless steel -60°C up to +450°C for function unit STN2 -60°C up to +300°C for function unit SFC up to +530°C with stainless steel body, bellows from Inconel 625 and function unit STN2		
Ambient temperature	-30°C up to +80°C		
Rangeability	40 : 1		
Leakage	Disc pair Carbon-stainless steel	Disc pair SFC	Disc pair STN 2
% of Kvs IEC 60534-4 EN 12266-1	< 0,0001 IV-S1 D	< 0,0005 IV-S1 E	< 0,001 IV E
Marking ATEX non electric	II 2G Ex h IIC T6...T1 X Gb II 2D Ex h IIIC 85°C...530°C X Db		
Spezific leakage rate shaft and body sealing	ISO FE-BH-CC3-SSA0-t(-40°C/+350°C)-PN40-ISO 15848-1		

* With DN15 with reduction of less than 25%, different leakage rates possible.
K_{vs}-values see data sheet 8001.

Fluid temperature

Rating	PN40	PN 16	PN 100	ANSI 150	ANSI 300	ANSI 600
Body material cpl. stainless steel						
Tmin [°C]	-60	-60	-60	-29	-29	-29
Tmax [°C]	530	530	530	530	530	530

Materials

Body	Stainless steel 1.4408	acier 1.0619
Bodycover	Stainless steel 1.4404 or 316L	
Diaphragm housing	Aluminium, KTL coated	
Packing	PTFE (Carbon filled), spring 1.4310	
Actuating stem	Stainless steel 1.4571, roller burnished	
Bellows	Stainless steel 1.4571	
Fixed disc	Stainless steel 1.4571, coated	STN2-disc
Sliding disc	Special carbon material	SFC-disc (max. 300°C) STN2-disc
Guide ring for sliding disc	Stainless steel 1.4581	

Options

- Metal bellows
- Positioner
 - pneumatic
 - electro-pneumatic
 - electro-pneumatic (Ex, intrinsically safe)
- Limit switches
- Position transmitter
- Manual override

Admissible differential pressures
(For temperatures of up to 120°C with PN-rating
up to 38°C with ANSI-rating)

**For temperatures of 120°C (PN)
or 38°C (ANSI) and above:
obey application limits !**

**Disc pair: carbon - stainless steel coated
SFC - stainless steel coated**

Actuator size	125 cm ²					250 cm ²				
	0.2 to 1.0	1.0 to 2.0	1.5 to 3.0	1.8 to 3.8	2.1 to 4.5	0.2 to 1.0	0.8 to 1.4	1.2 to 2.2	1.5 to 2.7	1.7 to 3.2
Spring range (bar)	1,2	2,8	4,2	5,2	6,0	1,2	2,1	3,2	4	4,6
Supply air (bar)	1,2	2,8	4,2	5,2	6,0	1,2	2,1	3,2	4	4,6
DN	Admissible differential pressures in bar									
15	4,4	100	100	100	100	18,9	100	100	100	100
20	3,8	100	100	100	100	16,4	100	100	100	100
25	3,2	88 (100)*	88 (100)*	88 (100)*	88 (100)*	13,7	88 (100)*	88 (100)*	88 (100)*	88 (100)*
32	2,6	100	100	100	100	11,3	100	100	100	100
40	2	66	88 (100)*	88 (100)*	88 (100)*	8,5	88 (100)*	88 (100)*	88 (100)*	88 (100)*
50	-	36	57	70	84	5,8	63	97	100	100
65	-	29	45	56	67	4,9	51	78	80	80
80	-	17	26	33	39	3,1	30	45	48	48
100	-	10	16	20	24	-	18	27	33	33
125	-	6,5	10	13	15	-	12	18	22	23
150	-	5	7,5	9	11	-	8,5	13	16	16
200	-	2,5	4,5	5,5	6,5	-	5	7,5	9	10
250	-	1,8	2,8	3,4	4,1	-	2,2	4,7	5,7	6,7
Spring configuration	Code D	Code 2	Code 3	Code 4	Code 5	Code D	Code 2	Code 3	Code 4	Code 5

Standard

*: figures in brackets for bodies of carbon steel

	Upper limits for admissible pressures in bar					
	PN16	PN40	PN100	ANSI150	ANSI 300	ANSI 600
P max. carbon steel	16	40	100	19,6	51,1	102,1
P max. stainless steel				19,0	49,6	99,3

Disc pair: STN 2

Actuator size	125 cm ²					250 cm ²				
	0.2 to 1.0	1.0 to 2.0	1.5 to 3.0	1.8 to 3.8	2.1 to 4.5	0.2 to 1.0	0.8 to 1.4	1.2 to 2.2	1.5 to 2.7	1.7 to 3.2
Spring range (bar)	1,2	2,8	4,2	5,2	6,0	1,2	2,1	3,2	4	4,6
Supply air (bar)	1,2	2,8	4,2	5,2	6,0	1,2	2,1	3,2	4	4,6
DN	Admissible differential pressures in bar									
15	3,1	100	100	100	100	13,4	100	100	100	100
20	2,4	57	100	100	100	10,3	100	100	100	100
25	1,8	57	88	88 (100)*	88 (100)*	7,7	88 (100)*	88 (100)*	88 (100)*	88 (100)*
32	1,3	38	59	73	87	5,7	66	100	100	100
40	0,9	23	37	45	54	3,9	41	63	72	72
50	-	13	20	25	30	2,4	23	35	42	49
65	-	10	16	20	24	2,0	18	28	34	40
80	-	6	9	11	14	1,2	10	16	19	23
100	-	3,5	5,5	7	8,5	-	6,5	10	12	14
125	-	2,5	3,5	4,5	5,5	-	4	6,5	8	9
150	-	1,5	2,5	3,5	4	-	3	4,5	5,5	6,5
Spring configuration	Code D	Code 2	Code 3	Code 4	Code 5	Code D	Code 2	Code 3	Code 4	Code 5

Standard

*: figures in brackets for bodies of carbon steel

	Upper limits for admissible pressures in bar					
	PN16	PN40	PN100	ANSI150	ANSI 300	ANSI 600
P max. carbon steel	16	40	100	19,6	51,1	102,1
P max. stainless steel				19,0	49,6	99,3

The supply air pressure stated in the table is the minimum supply air pressure that has to be available. This is valid for the usage without positioner. For the usage with positioner the required supply air pressure is being determined by the adjustment of the positioner. For the standard version it is 4 bar ü. The spring configuration "D" allows the usage of a control valve without positioner but with limited performance. The valve can be controlled directly by a process controller with the norm signal of 0,2 up to 1 bar.ww

Ordering Number System

1 2 3 4 5 6 7 8 9 10 11 12 13 14 15 16

8	0	2	3	/			V	Q				M				Z		S
---	---	---	---	---	--	--	---	---	--	--	--	---	--	--	--	---	--	---

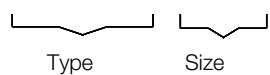

Symbol: "V": Valve
"R": Repair kit (sealings)

1 - 5 : Please quote all 5 sections.
6 - 16: Quote only if required.

1.	Function	2.	Body design	3.	Body materials	4.	Pilot function	5.	Actuator	6.	Special versions
Q	Control valve with pneumatic actuator (8023)	E F K G H	GS3-flangeless design acc. ANSI 150 GS3-flangeless design acc. ANSI 300 GS3-flangeless design acc. ANSI 600 GS3 - flangeless design acc. DIN, PN 10-PN 40 GS3 - flangeless design acc. DIN, PN 100	0 1	Carbon steel 1.0570/1.0619 stainless steel 1.4408/1.4404	0 1	spring to close spring to open	3 4	diaphragm actuator 125 cm ² diaphragm actuator 250 cm ²	M A C E H	to state, if some sections 7-16 are quoted nut and nut acc. DIN EN1092-1 nut and tongue acc. DIN EN1092-1 2x lowered face acc. DIN EN1092-1 lowered and raised face acc. DIN EN1092-1
7.	Springs	8.	Stem sealing	9.	Sliding disc	10.	Fixed disc	11.	Kvs-values	12.	Flow characteristic
- 1 2 3 4 5 D	Standard 2 springs 4 springs 6 springs 8 springs 10 springs Set of springs 0,2-1 bar (4 springs)	- 1 3	PTFE-V-shaped seal, self-adjusting (Standard) additional bellows 1.4571 additional inconel 625 bellow 2.4856	- 9 S	carbon material STN2 SFC	- 1	stainless steel 1.4571 coated STN 2-plate (only in combination with the position „9“ STN2-disc)	- A 1 B 2 C 3 4 5 6 7 8 9	100 % (Stand.) red. to 63 % red. to 40 % red. to 25 % red. to 16 % red. to 10 % red. to 6,3 % red. to 2,5 % red. to 1 % red. to 20 % red. to 12 % red. to 2 % red. to 0,4 %	- 1	linear Equal percentage
13.	Accessories	14.	Positioner	15.	Signalling equipment	16.	Special version				
Z	to state, if in sections 14 and 15 accessories are quoted	- 1 2 3 4 6 7	without p/p - without gauges p/p - with gauges i/p- without gauges dto. with gauges i/p- intrinsically safe, without gauges dto. without gauges	- 0 1 2 5	without 2 limit switches inductive, M12x1 10-30 V DC PNP 2 limit switches inductive, integrated in positioner i/p-converter 2 limit switches inductive, M 12x1 10-55 V DC PNP/NPN	S	other special versions have to be quoted in letters				

Ordering Example:

8023/080VQG103M4 - - - - Z3

GS3-Control Valve with pneumatic actuator, DN 80, PN 10/40, stainless steel, spring closes, actuator area 125 cm², 8 springs, PTFE-V-shaped sealings, function unit carbon-stainless steel 1.4571 coated, linear characteristic, i/p-positioner ex-proof

Application limitations for GS3 valves in stainless steel

These pressure must not be exceeded for GS-valves from the GS3-series made of stainless steel, even though the actuator power might allow it.

Application limits for carbon steel bodys on request.

PN40

DN	Sliding unit: carbon/SFC - stainless steel, coated							
	max. admissible pressures for GS3-valves in stainless steel							
	100°C	150°C	200°C	250°C	300°C	350°C	400°C	450°C
15	40	40	40	40	40	40	40	40
20	40	40	40	40	40	40	40	40
25	40	40	40	40	40	40	40	38
32	40	40	40	40	40	40	40	40
40	40	40	40	40	40	40	40	38
50	40	40	40	40	40	40	40	40
65	40	40	40	40	40	40	40	40
80	40	40	40	40	40	40	40	35
100	33	33	33	33	33	33	33	33
125	23	23	23	23	23	23	23	23
150	16	16	16	16	16	16	16	16
200 (only PN16)	16	16	15	13	12	11	10	9
250 (only PN16)	10	9	9	8	7	6	6	5

DN	Sliding unit: STN2									
	max. admissible pressures for GS3-valves in stainless steel									
	100°C	150°C	200°C	250°C	300°C	350°C	400°C	450°C	500°C	530°C
15	40	40	40	40	40	40	40	40	39	31
20	40	40	40	40	40	40	40	40	33	27
25	40	40	40	40	40	40	40	38	26	21
32	40	40	40	40	40	40	40	40	30	24
40	40	40	40	40	40	37	32	29	26	21
50	40	40	40	40	40	40	35	31	28	26
65	40	40	40	40	37	32	28	25	22	21
80	36	34	33	26	22	19	16	14	13	12
100	32	31	30	24	20	17	15	13	12	11
125	21	21	19	16	13	11	10	8	8	7
150	15	15	14	11	9	8	7	6	5	5
200 (only PN16)	-	-	-	-	-	-	-	-	-	-
250 (only PN16)	-	-	-	-	-	-	-	-	-	-

Limitation for SFC-sliding discs: 300°C

PN100

DN	Sliding unit: carbon/SFC - stainless steel, coated							
	max. admissible pressures for GS3-valves in stainless steel							
	100°C	150°C	200°C	250°C	300°C	350°C	400°C	450°C
15	100	100	100	93	84	79	74	55
20	100	100	89	81	73	68	64	48
25	88	81	70	63	57	54	51	38
32	100	93	80	73	65	62	58	43
40	88	81	70	63	57	54	51	38
50	100	100	100	100	100	94	87	76
65	80	80	80	79	71	67	63	47
80	48	48	48	48	48	44	41	35

DN	Sliding unit: STN2									
	max. admissible pressures for GS3-valves in stainless steel									
	100°C	150°C	200°C	250°C	300°C	350°C	400°C	450°C	500°C	530°C
15	100	100	100	93	84	79	74	55	39	31
20	100	100	89	81	73	68	64	48	33	27
25	88	81	70	63	57	54	51	38	26	21
32	100	93	80	73	65	60	52	43	30	24
40	72	69	65	53	43	37	32	29	26	21
50	77	73	70	56	46	40	35	31	28	26
65	62	59	56	45	37	32	28	25	22	21
80	36	34	33	26	22	19	16	14	13	12

Limitation for SFC-sliding discs: 300°C

ANSI150

DN	Sliding unit: carbon/SFC - stainless steel, coated									
	max. admissible pressures for GS3-valves in stainless steel									
	38°C	50°C	100°C	150°C	200°C	250°C	300°C	350°C	400°C	450°C
15-125	19,0	18,4	16,2	14,8	13,7	12,1	10,2	8,4	6,5	4,6
150	16,0	16,0	16,0	14,8	13,7	12,1	10,2	8,4	6,5	4,6
200	16,0	16,0	16,0	14,8	13,7	12,1	10,2	8,4	6,5	4,6
250	10,4	10,4	10,4	9,9	9,4	8,4	7,4	6,8	6,3	4,6

DN	Sliding unit: STN2											
	max. admissible pressures for GS3-valves in stainless steel											
	38°C	50°C	100°C	150°C	200°C	250°C	300°C	350°C	400°C	450°C	500°C	530°C
15-125	19,0	18,4	16,2	14,8	13,7	12,1	10,2	8,4	6,5	4,6	2,2	-1,0
150	16,2	16,2	16,2	14,8	13,7	11,8	9,7	8,4	6,5	4,6	2,2	-1,0
200	-	-	-	-	-	-	-	-	-	-	-	-
250	-	-	-	-	-	-	-	-	-	-	-	-

Limitation for SFC-sliding discs: 300°C

ANSI300

DN	Sliding unit: carbon/SFC - stainless steel, coated									
	max. admissible pressures for GS3-valves in stainless steel									
	38°C	50°C	100°C	150°C	200°C	250°C	300°C	350°C	400°C	450°C
15-65	49,6	48,1	42,2	38,5	35,7	33,4	31,6	30,3	29,4	28,8
80	48,0	48,0	42,2	38,5	35,7	33,4	31,6	30,3	29,4	28,8
100	33,0	33,0	33,0	33,0	33,0	33,0	31,6	30,3	29,4	28,8
125	23,0	23,0	23,0	23,0	23,0	23,0	23,0	23,0	23,0	23,0
150	16,0	16,0	16,0	16,0	16,0	16,0	16,0	16,0	16,0	16,0

DN	Sliding unit: STN2											
	max. admissible pressures for GS3-valves in stainless steel											
	38°C	50°C	100°C	150°C	200°C	250°C	300°C	350°C	400°C	450°C	500°C	530°C
15	49,6	48,1	42,2	38,5	35,7	33,4	31,6	30,3	29,4	28,8	27,6	25,8
20	49,6	48,1	42,2	38,5	35,7	33,4	31,6	30,3	29,4	28,8	27,6	25,8
25	49,6	48,1	42,2	38,5	35,7	33,4	31,6	30,3	29,4	28,8	26,6	21,7
32	49,6	48,1	42,2	38,5	35,7	33,4	31,6	30,3	29,4	28,8	27,6	24,9
40	49,6	48,1	42,2	38,5	35,7	33,4	31,6	30,3	29,4	28,8	26,6	21,7
50	49,6	48,1	42,2	38,5	35,7	33,4	31,6	30,3	29,4	28,8	27,6	25,8
65	49,6	48,1	42,2	38,5	35,7	33,4	31,6	30,3	28,4	25,2	22,8	21,6
80	36,6	36,6	36,6	34,8	33,0	26,8	22,0	19,0	16,6	14,7	13,3	12,5
100	33,0	33,0	33,0	31,7	30,1	24,4	20,1	17,3	15,1	13,4	12,2	11,5
125	22,0	22,0	22,0	21,0	19,9	16,1	13,2	11,5	10,0	8,9	8,0	7,5
150	16,0	16,0	16,0	15,4	14,6	11,8	9,7	8,4	7,3	6,5	5,9	5,5

Limitation for SFC-sliding discs: 300°C

ANSI600

DN	Sliding unit: carbon/SFC - stainless steel, coated									
	max. admissible pressures for GS3-valves in stainless steel									
	38°C	50°C	100°C	150°C	200°C	250°C	300°C	350°C	400°C	450°C
15	99,3	96,2	84,4	77,0	71,3	66,8	63,2	60,7	59,8	55,7
20	99,3	96,2	84,4	77,0	71,3	66,8	63,2	60,7	59,8	48,3
25	88,0	88,0	84,4	77,0	70,1	63,7	57,3	54,2	51,0	38,0
32	99,3	96,2	84,4	77,0	71,3	66,8	63,2	60,7	58,5	43,6
40	88,0	88,0	84,4	77,0	70,1	63,7	57,3	54,2	51,0	38,0
50	99,3	96,2	84,4	77,0	71,3	66,8	63,2	60,7	59,8	57,7
65	80,0	80,0	80,0	77,0	71,3	66,8	63,2	60,7	59,8	47,5
80	48,0	48,0	48,0	48,0	48,0	48,0	48,0	44,5	41,1	35,4

DN	Sliding unit: STN2											
	max. admissible pressures for GS3-valves in stainless steel											
	38°C	50°C	100°C	150°C	200°C	250°C	300°C	350°C	400°C	450°C	500°C	530°C
15	99,3	96,2	84,4	77,0	71,3	66,8	63,2	60,7	59,8	55,7	39,0	31,8
20	99,3	96,2	84,4	77,0	71,3	66,8	63,2	60,7	59,8	48,3	33,9	27,6
25	88,0	88,0	84,4	77,0	70,1	63,7	57,3	54,2	51,0	38,0	26,6	21,7
32	99,3	96,2	84,4	77,0	71,3	66,8	63,2	60,2	52,6	43,6	30,5	24,9
40	72,5	72,5	72,5	69,0	65,5	53,1	43,6	37,7	32,9	29,2	26,5	21,7
50	77,7	77,7	77,7	73,9	70,2	56,9	46,7	40,4	35,3	31,3	28,4	26,9
65	62,5	62,5	41,7	59,5	56,4	45,8	37,6	32,5	28,4	25,2	22,8	21,6
80	36,6	36,6	36,6	34,8	33,0	26,8	22,0	19,0	16,6	14,7	13,3	12,6

Limitation for SFC-sliding discs: 300°C

Application limitations for GS3 valves in carbon steel

These pressure must not be exceeded for GS-valves from the GS3-series made of carbon steel, even though the actuator power might allow it.

PN40

Sliding unit: carbon/SFC - stainless steel, coated								
max. admissible pressures for GS3-valves in carbon steel								
DN	100°C	150°C	200°C	250°C	300°C	350°C	400°C	450°C
15-32	40	40	40	40	40	40	40	40
40	40	40	40	40	40	40	40	40
50	40	40	40	40	40	40	40	40
65	40	40	40	40	40	40	40	40
80	40	40	40	40	40	40	40	38
100	33	33	33	33	33	33	33	33
125	23	23	23	23	23	23	23	23
150	16	16	16	16	16	16	16	16
200 (only PN16)	16	16	15	13	12	11	10	9
250 (only PN16)	10	9	9	8	7	6	6	5

Sliding unit: STN2								
max. admissible pressures for GS3-valves in carbon steel								
DN	100°C	150°C	200°C	250°C	300°C	350°C	400°C	450°C
15-32	40	40	40	40	40	40	40	40
40	40	40	40	40	40	40	32	29
50	40	40	40	40	40	40	35	31
65	40	40	40	40	37	32	28	25
80	36	34	33	26	22	19	16	14
100	33	31	30	24	20	17	15	13
125	22	21	19	16	13	11	10	8
150	16	15	14	11	9	8	7	6
200 (only PN16)	-	-	-	-	-	-	-	-
250 (only PN16)	-	-	-	-	-	-	-	-

Limitation for SFC-sliding discs: 300°C

PN100

Sliding unit: carbon/SFC - stainless steel, coated								
max. admissible pressures for GS3-valves in carbon steel								
DN	100°C	150°C	200°C	250°C	300°C	350°C	400°C	450°C
15	100	100	100	100	100	100	93	71
20	100	100	100	100	100	100	100	80
25	100	100	100	100	94	87	81	62
32	100	100	100	100	100	99	93	72
40	100	100	100	100	94	87	81	63
50	100	100	100	100	100	94	87	81
65	80	80	80	80	80	76	70	65
80	48	48	48	48	48	44	41	38

Sliding unit: STN2								
max. admissible pressures for GS3-valves in carbon steel								
DN	100°C	150°C	200°C	250°C	300°C	350°C	400°C	450°C
15	100	100	100	100	100	100	93	71
20	100	100	100	100	100	100	100	80
25	100	100	100	100	94	87	79	62
32	100	100	100	84	69	60	52	46
40	72	69	65	53	43	37	32	29
50	77	73	70	56	46	40	35	31
65	62	59	56	45	37	32	28	25
80	36	34	33	26	22	19	16	14

Limitation for SFC-sliding discs: 300°C

125	16	16	16	16	13	11	10	8
150	16	15	14	11	9	8	7	6
200	-	-	-	-	-	-	-	-
250	-	-	-	-	-	-	-	-

Limitation for SFC-sliding discs: 300°C

ANSI 150

Sliding unit: carbon/SFC - stainless steel, coated										
max. admissible pressures for GS3-valves in carbon steel										
DN	38°C	50°C	100°C	150°C	200°C	250°C	300°C	350°C	400°C	450°C
15-125	19,6	19,2	17,7	15,8	13,8	12,1	10,2	8,4	6,5	4,6
150	16,0	16,0	16,0	15,8	13,8	12,1	10,2	8,4	6,5	4,6
200	16,0	16,0	16,0	15,8	13,8	12,1	10,2	8,4	6,5	4,6
250	10,5	10,5	10,5	9,9	9,4	8,4	7,4	6,0	6,4	4,6

Sliding unit: STN2										
max. admissible pressures for GS3-valves in carbon steel										
DN	38°C	50°C	100°C	150°C	200°C	250°C	300°C	350°C	400°C	450°C
15-125	19,6	19,2	17,7	15,8	13,8	12,1	10,2	8,4	6,5	4,6
150	16,2	16,2	16,2	15,4	13,8	11,8	9,7	8,0	6,5	4,6
200	-	-	-	-	-	-	-	-	-	-
250	-	-	-	-	-	-	-	-	-	-

Limitation for SFC-sliding discs: 300°C

ANSI 300

Sliding unit: carbon/SFC - stainless steel, coated										
max. admissible pressures for GS3-valves in carbon steel										
DN	38°C	50°C	100°C	150°C	200°C	250°C	300°C	350°C	400°C	450°C
15-25	51,1	50,1	46,6	45,1	43,8	41,9	39,8	37,6	34,7	23,0
32	51,1	50,1	46,6	45,1	43,8	41,9	39,8	37,6	34,7	23,0
40	51,1	50,1	46,6	45,1	43,8	41,9	39,8	37,6	34,7	23,0
50	51,1	50,1	46,6	45,1	43,8	41,9	39,8	37,6	34,7	23,0
65	51,1	50,1	46,6	45,1	43,8	41,9	39,8	37,6	34,7	23,0
80	48,0	48,0	46,6	45,1	43,8	41,9	39,8	37,6	34,7	23,0
100	33,0	33,0	33,0	33,0	33,0	33,0	33,0	37,6	33,0	23,0
125	23,0	23,0	23,0	23,0	23,0	23,0	23,0	23,0	23,0	23,0
150	16,0	16,0	16,0	16,0	16,0	16,0	16,0	16,0	16,0	16,0

Sliding unit: STN2										
max. admissible pressures for GS3-valves in carbon steel										
DN	38°C	50°C	100°C	150°C	200°C	250°C	300°C	350°C	400°C	450°C
15-25	51,1	50,1	46,6	45,1	43,8	41,9	39,8	37,6	34,7	23,0
32	51,1	50,1	46,6	45,1	43,8	41,9	39,8	37,6	34,7	23,0
40	51,1	50,1	46,6	45,1	43,8	41,9	39,8	37,6	32,9	23,0
50	51,1	50,1	46,6	45,1	43,8	41,9	39,8	37,6	34,7	23,0
65	41,7	41,7	41,7	39,7	37,6	33,5	37,6	32,5	28,4	23,0
80	36,6	36,6	36,6	34,8	33,0	26,8	22,0	19,0	16,6	14,7
100	33,0	33,0	33,0	31,7	30,1	24,4	20,0	17,0	15,1	13,4
125	22,1	22,1	22,1	21,0	19,9	16,1	13,2	11,0	10,0	8,9
150	16,0	16,0	16,0	15,4	14,6	11,8	9,7	8,0	7,3	6,5

Limitation for SFC-sliding discs: 300°C

ANSI 600

Sliding unit: carbon/SFC - stainless steel, coated										
max. admissible pressures for GS3-valves in carbon steel										
DN	38°C	50°C	100°C	150°C	200°C	250°C	300°C	350°C	400°C	450°C
15-25	102,1	100,2	93,2	90,2	87,6	83,9	79,6	75,1	69,4	46,0
32	102,1	100,2	93,2	90,2	87,6	83,9	79,6	75,1	69,4	46,0
40	100,0	100,0	93,2	90,2	87,6	83,9	79,6	75,1	69,4	46,0
50	100,0	100,0	93,2	90,2	87,6	83,9	79,6	75,1	69,4	46,0
65	80,0	80,0	80,0	80,0	80,0	80,0	79,6	75,1	69,4	46,0
80	48,0	48,0	48,0	48,0	48,0	48,0	48,0	44,0	41,1	38,3

Sliding unit: STN2										
max. admissible pressures for GS3-valves in carbon steel										
DN	38°C	50°C	100°C	150°C	200°C	250°C	300°C	350°C	400°C	450°C
15-25	102,1	100,2	93,2	90,2	87,6	83,9	79,6	75,1	69,4	46,0
32	102,1	100,2	93,2	90,2	87,6	83,9	69,6	60,0	52,6	46,0
40	72,5	72,5	72,5	69,0	65,5	53,1	43,6	37,0	32,9	29,2
50	77,7	77,7	77,7	73,9	70,2	56,9	46,7	40,0	35,3	31,3
65	62,5	62,5	62,5	59,5	56,4	45,8	37,6	32,0	28,4	25,2
80	36,6	36,6	36,6	36,8	33,0	26,8	22,0	19,0	16,6	14,7

Limitation for SFC-sliding discs: 300°C

Dimensions and Weights

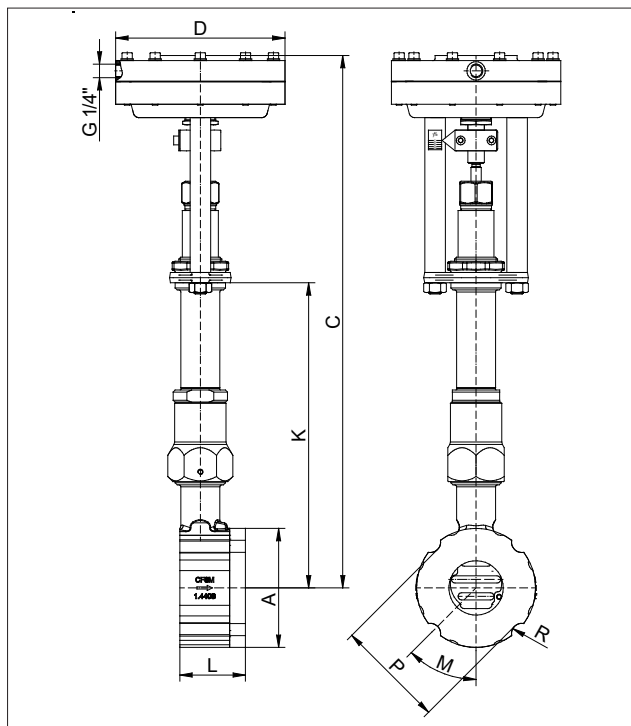

without positioner

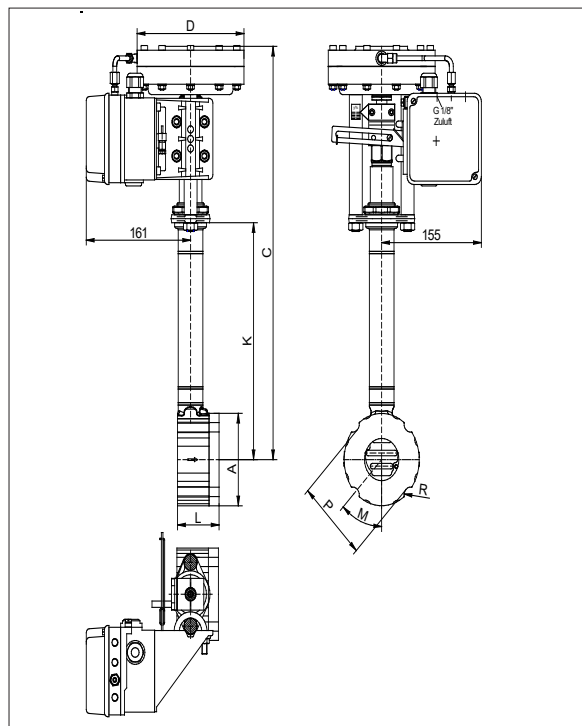

with electropneumatic positioner

DN	A mm	C mm	Ø D actuator size		K mm	L mm	Weight kg actuator size		Stroke mm
			125	250			125	250	
15	64	495	165	222	272	56	7,5	9,7	6
20	72	500	165	222	276	56	7,7	9,9	6
25	82	505	165	222	281	56	8,2	10,4	6
32	89	510	165	222	283	56	8,5	10,7	6
40	99	515	165	222	289	56	9	11	6
50	116	525	165	222	297	64	10,5	13	8
65	138	535	165	222	306	68	12,5	15	8
80	153	545	165	222	315	70	13,5	16	8
100	184	555	165	222	328	75	16,5	19	8,5
125	212	570	165	222	343	80	19,5	22	8,5
150	242	585	165	222	356	80	23	25	8,5
200	302	615	165	222	384	93	40	42	8,5
250	360	640	165	222	410	96	45,5	47,5	8,5

Dimensions in mm