

GS 1 series, DN 15 up to DN 150

Fast and high resolution motor valve for control and switching of neutral through to highly aggressive media in process engineering, chemical industries and for plant equipment.

- Space saving wafer type construction
- Lowest possible weight (especially in larger sizes)
- Low operation noise level (quiet operation)
- Control of high differential pressures with small actuators
- Fast stroking speed
- Small dead band
- Smooth start and slow down
- Metall body



Technical Information of the Valve

Design	flangeless, wafer type construction dimensions acc. DIN EN 558-1 series 20 for flanges acc. DIN EN 1092-1 form B more versions see data-sheet 8038-GS3		
Nominal sizes	DN 15 up to DN 150		
Nominal pressure	PN 40 acc. DIN 2401 also for flanges PN 10 up to PN 25		
Fluid temperature	body 1.0570: -10°C up to +350°C body 1.4571: -60°C up to +350°C		
Rangeability	40 : 1		
Leakage *	Disc pair Carbon-stainless steel	Disc pair SFC	Disc pair STN 2
% of Kvs	< 0,0001	< 0,0005	< 0,001
IEC 60534-4	IV-S1	IV-S1	IV
EN 12266-1	D	E	E
Packing leakage	tested according to TA-Luft as defined in DIN EN ISO 15848-1 and VDI 2440		

* With DN15 with reduction of less than 25%, different leakage rates possible.
K_{vs}-values see data sheet 8001.

Materials of the Valve

Body	carbon steel 1.0619	stainless steel 1.4581 or 1.4408	
Packing	PTFE (carbon filled), spring 1.4310		
Actuating stem	stainless steel, roller burnished		
Bellow	stainless steel 1.4571		
Fixed disc	stainless steel 1.4571, plated	STN2-disc	
Sliding disc	standard: special carbon material	SFC-disc (max. 300°C)	STN2-disc
Coupling ring for disc	stainless steel 1.4581		

Technical Information of the Actuator

Driving force	2,0 kN / 5,0 kN
Power connections	24 V AC/DC 100 - 240 V 50/60Hz
Ambient temperature	Standard: -10°C up to +60°C Low temperature version: -40°C up to +60°C
Storage Temperature	Standard: -30°C up to +80°C (+60°C with Fail-Safe protection) Low temperature version: -40°C up to +80°C (+60°C with Fail-Safe protection)
Mounting position	choice horizontal or vertical actuator only
Protection class (EN 60529)	IP 67
Max. power consumption	40 Watt
Stroking speed	2,0 kN-version: 0,75 s/mm up to 250 s/mm (standard 1,5 s/mm) 5,0 kN-version: 2 s/mm up to 250 s/mm (standard 4 s/mm)
Stroking speed of the Fail-Safe protection	2,0 kN-version: 0,75 s/mm up to 4 s/mm 5,0 kN-version: 2 s/mm up to 4 s/mm
Set point range	adjustable 0(4) - 20 mA, 0(2) - 10 V optional binary input signal (24V DC)
Feed back	adjustable 0(4) - 20 mA, 0(2) - 10 V
cycles (Fail-Safe)	500.000
life-time (Fail-Safe)	10 years
duty cycle	100%
Self Monitoring	monitoring of the driving power, set point, actuator temperature, temperature of the electronic etc.
Diagnostic function	storage of motor and total service life, temperature- and way classes
Valve adaptation	automatic stroke adjustment to suit valve limits
additional inputs	binary input
additional outputs	2 alarm outputs

Stroking Times

DN	Stroke	Stroking time (sec.) for the complete stroke at a stroking speed of				
		0,75 s/mm	1 s/mm	1,5 s/mm	2 s/mm	4 s/mm
15 - 40	6,25	4,7	6,3	9,4	12,5	25,0
50 - 80	8,25	6,2	8,3	12,4	16,5	33,0
100 - 250	8,75	6,6	8,8	13,1	17,5	35,0
				Standard 2kN-actuator	min. stroking time for 5kN-actuator	Standard 5kN-actuator

Options

2 additional stroke limit switches	free adjustable volt free contacts (open/close)
Fail safe protection	Mounted in own body at actuator Safety position freely selectable
Communication software	with communication link, for parametrization and diagnosis of the actuator
Bluetoothmodul BT-1	Wireless connection to DeviceConfig configuration software (upgrade option)

Actuator with Fail-Safe protection (Option)

- Safety function at power failure
- Power supply via high performance capacitors
- Safety position open, closed or in every other position selectable
- Automatic monitoring of the charge condition of the capacitors

Admissible Differential Pressures

DN	driving force: 2kN		driving force: 5kN	
	max. differential pressure (bar)			
	disc - pair carbon/SFC stainless steel coated	disc - pair STN2	disc - pair carbon/SFC stainless steel coated	disc - pair STN2
15	40	40	40	40
20	40	40	40	40
25	40	40	40	40
32	40	40	40	40
40	40	26	40	40
50	40	22	40	40
65	40	18	40	37
80	27	10	40	22
100	17	7	24	13
125	12	4,5	16	8
150	9	3	16	8

Application limits for GS1-Valves

PN 40

DN	Sliding unit: carbon/SFC - stainless steel, coated						Sliding unit: carbon - STN2					
	max. admissible pressures for GS1-valves						max. admissible pressures for GS1-valves					
	100°C	150°C	200°C	250°C	300°C	350°C	100°C	150°C	200°C	250°C	300°C	350°C
15 - 25	40	36	31	28	26	24	40	36	31	28	26	24
32	40	36	31	28	26	24	40	36	31	28	25	22
40	40	36	31	28	26	24	26	25	24	19	16	14
50	40	36	31	28	26	24	40	36	31	28	26	24
65	40	36	31	28	26	24	37	35	31	27	22	19
80	40	36	31	28	26	24	22	20	19	16	13	11
100	24	23	22	19	17	16	13	12	12	9	8	6
125	16	15	14	13	11	10	8	8	7	6	5	4
150	16	16	16	16	14	13	10	10	9	7	6	5

Limitation for SFC-sliding discs: 300°C

Ordering Number System

8	0	3	8	/					V	T					M						Z			S

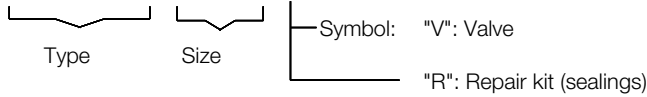

1 - 5 : Please quote all 5 sections.
6 - 16: Quote only if required.

1. Function	2. Body design	3. Body material	4. Security position	5. Actuator	6. Special versions	7. Motor voltages	8. Stem sealing
T GS-motor valve type 8038	0 flangeless design for flanges acc. DIN 2632-2635 (PN10-PN40)	0 carbon-steel 1.0570 / 1.0619 1 stainless steel 1.4581 or 1.4408	- without 1 Fail Safe Function: Safety position closed in the case of power failure 2 Fail Safe Function: Safety position opened in the case of power failure 3 Fail Safe Function: position in case of power failure accor- ding to customer specification	A 2 kN, position- electronic, IP67 B 5 kN, position- electronic, IP67 L 2 kN, position- electronic, low-temperature version IP67	M to state, if some sections 7-21 are quoted	- 100 - 240V 50/60 Hz (Standard) 1 24V AC/DC	- PTFE-V- shaped seal, self- adjusting (Standard) 1 additional stainless steel below 1.4571 (max. 33 bar pressure)
9. Sliding disc	10. Fixed disc	11. Kvs-values	12. Seat characteristics	13. Accessories	14. Input signal	15. Limit switches	16. Special versions
- carbon material 9 STN2 S SFC	- stainless steel 1.4581, hard- chrome plated 1 STN2 (only in combination with the position "9" STN2-disc)	- 100 % (Stand.) A red. to 63 % 1 red. to 40 % 2 red. to 16 % 3 red. to 6.3 % 4 red. to 2.5 % 5 red. to 1 % 6 red. to 20 % 7 red. to 12 % 8 red. to 2 % 9 red. to 0,4 %	- linear 1 equal percentage	Z to state, if in sections 14 et seq. are quoted	- standard 4-20 mA or 2-10 V 3 0-20mA or 0-10V A binary control 24V DC - 3-point	- without 2 2 limit switches	S other special versions/ accessory
17. Stroking time	18. Special treatment	19. Feedback	20. Settings	21. Special additional version			
- Standard (2kN=1,5 s/mm; 5kN=4s/mm) 1 0,75 s/mm 2 1 s/mm 3 2 s/mm 4 4 s/mm	- standard 1 for oxygen 2 silicon-free	- standard (at control actuators like control signal)	- standard death band ±0,2%	- without			

Ordering example: 8038/100VT01 - AM- - - - - Z - 2
 GS1-control valve with motor actuator, DN 100, PN 10/40, stainless steel,
 actuator 2 kN, 100-240V 50/60 Hz, PTFE-packing, discs: carbon - stainless steel 1.4571
 coated, seat characteristics linear, 2 limit switches

Dimensions and Weights

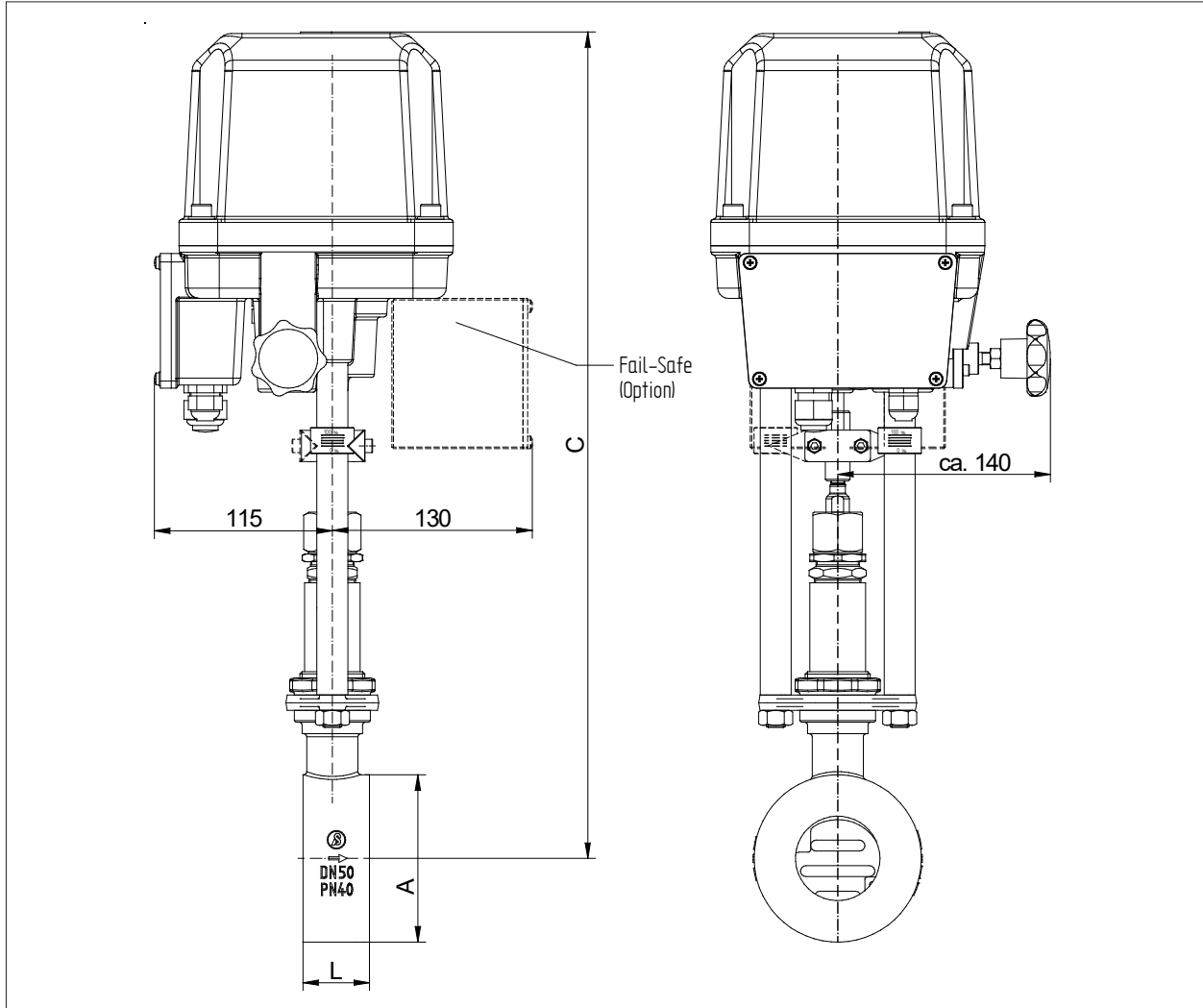

DN	ØA	C		L	Stroke	weight 2kN-Actuator kg		weight 5kN-Actuator kg	
		2kN	5kN			without Fail-Save	with Fail-Save	without Fail-Save	with Fail-Save
15	53	507	539	33	6	10,2	12	11,1	12,9
20	62	512	544	33	6	10,3	12,1	11,2	13
25	72	517	549	33	6	10,5	12,3	11,4	13,2
32	82	522	554	33	6	10,8	12,6	11,7	13,5
40	92	527	559	33	6	11	12,8	11,9	13,7
50	108	537	569	43	8	12,2	14	13,1	14,9
65	127	547	579	46	8	13	14,8	13,9	15,7
80	142	557	589	46	8	13,6	15,4	14,5	16,3
100	164	567	599	52	8,5	15,1	16,9	16	17,8
125	194	582	614	56	8,5	18,8	20,6	19,7	21,5
150	219	597	629	56	8,5	20,7	22,5	21,6	23,4

Dimensions in mm