



Serie **EUROFLY**

Articolo **600105**

**DISC INOX**

Butterfly valve WAFER type PN 16, body in cast iron G250 + Epoxy painting, EPDM seat.

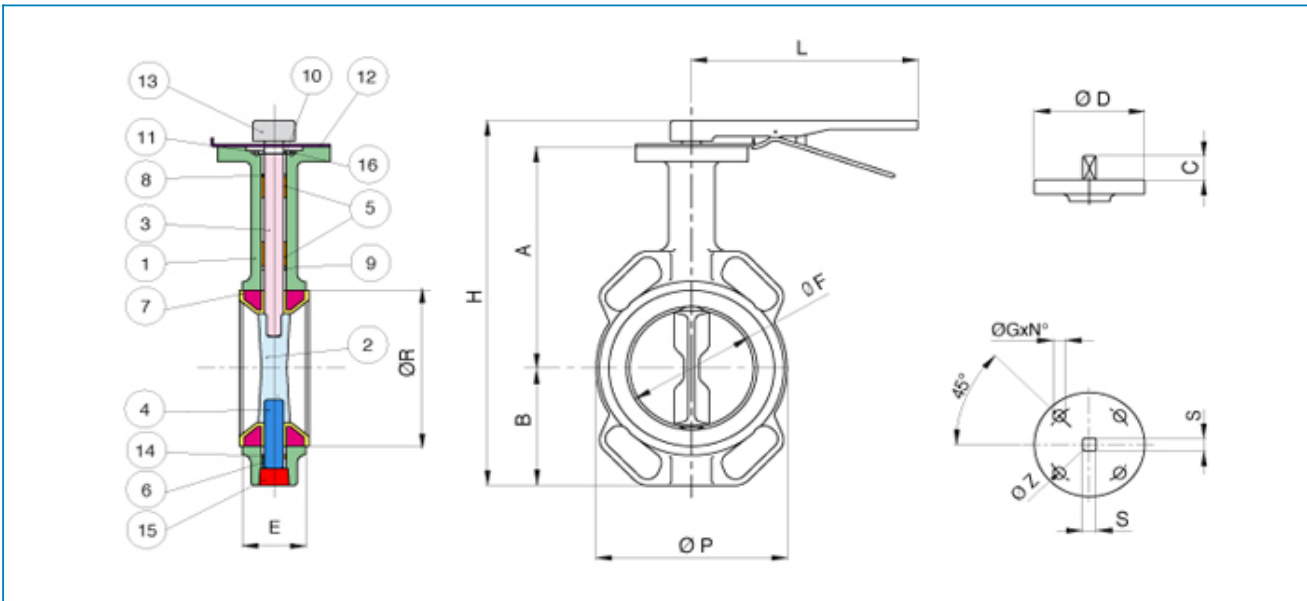

Limiti di temperatura:  $-10^{\circ} +120^{\circ}$  - Temperature range:  $-10^{\circ} +120^{\circ}$

POS.	PART NAME	MATERIALE-MATERIALS MATERIAUX-WERKSTOFF- MATERIAL	N°P
1	BODY	EN-GJL 250	1
2	DISC	A351-CF8M	1
3	STEM	SS416	1
4	STEM	SS416	1
5	STEM SEAT	PTFE	1
6	STEM SEAT	PTFE	1
7	SEAT	EPDM	1
8	O-RING	EPDM	1
9	O-RING	EPDM	1
10	WASHER	CARBON STEEL	1
11	CIRCLIP	SPRING STEEL	1
12	RETAINER	CARBON STEEL	1
13	LEVER	EN-GJL 250	1
14	O-RING	EPDM	1
15	CAP	CARBON STEEL	1
16	SCREW	CARBON STEEL	2

MISURA / DN SIZE / DN	H	A	B	L	ØF	ØP	ØR	E	ØD	C	ØG	N°	ØZ	S	Kv	PN	Kg
32	190	112	58	162	35	85	56	33	90	22	7/10	4	50/70	11	-	PN16 - ANSI 150	2,04
40	204	112	70	162	41	95	68	33	90	22	7/10	4	50/70	11	-	PN16 - ANSI 150	2,30
50	236,1	142,7	71,4	267	52,25	100	73,3	43	90	22	7/10	4	50/70	11	-	PN16 - ANSI 150	3,24
65	255,2	155,4	77,8	267	64,05	120	86	46	90	22	7/10	4	50/70	11	-	PN16 - ANSI 150	3,88
80	272,8	161,8	89	267	78,65	127	100,9	46	90	22	7/10	4	50/70	11	-	PN16 - ANSI 150	4,18
100	302	178	102	267	104,15	161	132	52	90	22	10	4	70	14	-	PN16 - ANSI 150	5,36
125	335,5	190,5	123	267	123,35	190	156	56	90	22	10	4	70	14	-	PN16 - ANSI 150	7,10
150	365,2	205,2	138	267	155,85	215	185,4	56	90	22	10	4	70	14	-	PN16 - ANSI 150	8,28
200	439,5	237	168	358	202,55	268	235,2	60	150	34,5	12	4	102	17	-	PN16 - ANSI 150	13,70
250	509,8	268,3	207	358	250,55	325	289,4	68	150	34,5	12	4	102	22	-	PN16 - ANSI 150	21,82
300	586,5	308,5	243,5	358	301,65	400	341,2	78	150	34,5	14	4	125	27	-	PN16 - ANSI 150	32,09
350*	-	-	-	-	-	-	-	-	-	-	-	-	-	-	-	PN10	-
400*	-	-	-	-	-	-	-	-	-	-	-	-	-	-	-	PN10	-
450*	-	-	-	-	-	-	-	-	-	-	-	-	-	-	-	PN10	-
500*	-	-	-	-	-	-	-	-	-	-	-	-	-	-	-	PN10	-
600*	-	-	-	-	-	-	-	-	-	-	-	-	-	-	-	PN10	-

\* Incluso riduttore di manovra manuale - Gear operator included