

**Mechanical
pressure measurement**

**Diaphragm pressure gauge
Industrial series, grey cast iron
Models 422.12, 423.12**

WIKA data sheet PM 04.02



for further approvals
see page 3

Applications

- For measuring points with increased overpressure
- With liquid-filled case for applications with high dynamic pressure loads or vibrations ¹⁾
- For gaseous and liquid media, with the open connecting flange option also for particulates-containing and viscous media
- For mining, environmental technology, machine building and general plant construction

Special features

- Compatible with switch contacts
- Process connection thread or open flange
- Scale ranges from 0 ... 16 mbar



Diaphragm pressure gauge model 422.12

Description

Design
EN 837-3

Nominal size in mm
100, 160

Accuracy class
1.6

Scale ranges
0 ... 16 mbar to 0 ... 250 mbar (flange Ø 160 mm)
0 ... 400 mbar to 0 ... 40 bar (flange Ø 100 mm)
or all other equivalent vacuum or combined pressure and vacuum ranges

Pressure limitation
Steady: full scale value
Fluctuating: 0.9 x full scale value

Overpressure safety
3 x full scale value, however max. 40 bar

Permissible temperature
Ambient: -20 ... +60 °C
Medium: +100 °C maximum
Storage: -40 ... +70 °C (scale ranges ≤ 60 mbar:
-20 ... +70 °C)

Temperature effect
When the temperature of the measuring system deviates from the reference temperature (+20 °C):
max. ±0.8 %/10 K of full scale value

Ingress protection
IP 54 per EN 60529 / IEC 60529
(with liquid filling ¹⁾ IP 65)

¹⁾ Model 423.12

WIKA data sheet PM 04.02 - 02/2014

Page 1 of 3

Data sheets showing similar products:
Electrical switch contacts; models 8x1 and model 830; see data sheet AC 08.01
Diaphragm pressure gauges, stainless steel version; model 432.50; see data sheet PM 04.03
Elastic element pressure gauges; see data sheet IN 00.01



Standard version

Process connection with lower measuring flange
Steel, lower mount (LM), G 1/2 B (male), 27 mm flats

Pressure element
≤ 2.5 bar: Stainless steel 1.4571
> 2.5 bar: Stainless steel 1.4568

Pressure chamber sealing
NBR

Movement
Cu-alloy, wear parts argentan

Dial
Aluminium, white, black lettering

Pointer
Aluminium, black

Case with upper measuring flange
Grey cast iron, black

Window
Instrument glass

Bezel ring
Cam ring (bayonet type), stainless steel, black

Filling liquid ²⁾ (for model 423.12)
Glycerine 86.5 %

²⁾ Accuracy class 2.5

Options

- Other process connection
- Sealings (model 910.17, see data sheet AC 09.08)
- Wetted parts made of stainless steel, pressure chamber sealing FPM/FKM (model 432.12)
- Overpressure safety: 10 x full scale value, max. 40 bar
- Vacuum safe up to -1 bar
- Open connecting flanges per DIN/ASME from DN 15 to DN 80 (preferred nominal widths DN 25 and 50 or DN 1" and 2" per data sheet IN 00.10)
- Pressure element > 2.5 bar: NiCr-alloy (Inconel)
- Switch contacts ²⁾ (see data sheet AC 08.01)

Dimensions in mm
Standard version

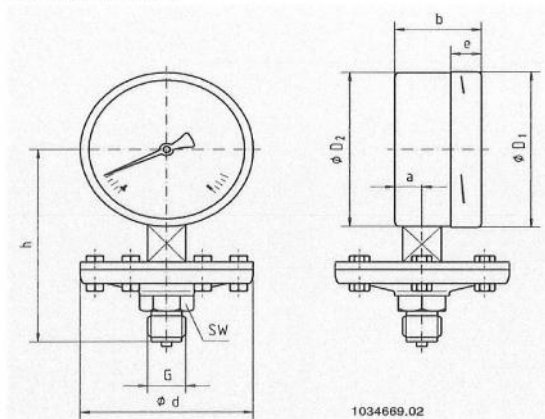

NS	Scale range in bar	Dimensions in mm								Weight	
		d	a	b	D ₁	D ₂	e	G	h ±2	SW	in kg
100	≤ 0.25	160	15.5	49.5	101	99	17.5	G 1/2 B	135	27	3.4
160	≤ 0.25	160	15.5	49.5	161	159	17.5	G 1/2 B	165	27	4.3
100	> 0.25	100	15.5	49.5	101	99	17.5	G 1/2 B	135	27	2.1
160	> 0.25	100	15.5	49.5	161	159	17.5	G 1/2 B	165	27	3.0

Process connection per EN 837-3 / 7.3.

Approvals

- **GOST**, metrology/measurement technology, Russia
- **GOST-R**, import certificate, Russia
- **CRN**, safety (e.g. electr. safety, overpressure, ...), Canada

Certificates ¹⁾

- 2.2 test report per EN 10204 (e.g. state-of-the-art manufacturing, material proof, indication accuracy)
- 3.1 inspection certificate per EN 10204 (e.g. material proof wetted parts metal component, indication accuracy)

1) Option

Approvals and certificates, see website

Ordering information

Model / Nominal size / Scale range / Connection size / Connection location / Options

© 2008 WIKA Alexander Wiegand SE & Co. KG, all rights reserved.
The specifications given in this document represent the state of engineering at the time of publishing.
We reserve the right to make modifications to the specifications and materials.

WIKA data sheet PM 04.02 · 02/2014

Page 3 of 3

02/2014 GB



WIKA Alexander Wiegand SE & Co. KG
Alexander-Wiegand-Straße 30
63911 Klingenberg/Germany
Tel. +49 9372 132-0
Fax +49 9372 132-406
info@wika.de
www.wika.de

Art. No.	Ident No.
PL 1901	102584
PL 1911	102585
PL 1912	102586
PL 1913	102587
PL 1914	102588
PL 1915	102589
PL 1916	102590
PL 1917	102591
PL 1918	102592