

Series K8P electronic proportional micro regulator

Proportional regulator for the pressure control



- » High precision
- » Reduced response times
- » Minimum consumption
- » Self-regulation function
- » Flexibility of use
- » Compact design

The K8P regulator adjusts the outlet pressure through the operation of two K8 monostable valves according to the inlet signal and to the retroactivity of the internal pressure sensor. A self-adjusting function has been integrated into the regulator control algorithm to guarantee the highest levels of performance apart from the volume connected.

Series K8P electronic proportional micro regulators have evolved from our Series K8 mini-solenoid valves. Series K8P regulators guarantee excellent pressure regulation, fast response times, self-regulation and low energy consumption. Series K8P is a high performance proportional pressure regulator which is suitable for use in all applications where high precision, quick response times and low consumption are required.

GENERAL DATA

Fluids	filtered compressed air, unlubricated, according to ISO 8573-1 class 3.4.3, inert gas		
Range of regulated pressure	0.5 ÷ 10 bar 0.15 ÷ 3 bar		
Max inlet pressure	11 bar (0.5 ÷ 10 bar) 4 bar (0.15 ÷ 3 bar)		
Operating pressure	0 ÷ +50°C		
Analogical input	0-10 V DC	4-20 mA	Ripple ≤ 0,2%
Analogical output	0.5 - 9.5 V [Feedback]		
Analog input impedance	20.000 Ω for versions 0-10 V 250 Ω for versions 4-20 mA		
Maximum flow	Inlet P 10 bar - regulated P 6 bar 12 l/min Inlet P 4 bar - regulated P 3 bar 6 l/min		
Supply / Use	24 V - ~1 W		
Function	3/2 NC		
Linearity	≤ ± 1% FS		
Hysteresis	±0,5% FS		
Repeatability	±0,5% FS		
Minimal set point change	50 mV => 50 mB (10 bar) - 100mV => 30 mB (3 bar)		
Electrical connection	M8 4 Pin (Male)		

In compliance with the European Directive 2004/108/EC

CODING EXAMPLE

K8P	-	0	-	D	5	2	2	-	0
------------	----------	----------	----------	----------	----------	----------	----------	----------	----------

K8P	SERIES
0	BODY DESIGN: 0 = Stand alone S = Standard Sub-base L = Light Sub-base T = Light Sub-base for the pressure remote reading
D	WORKING PRESSURE: D = 0 -10 bar E = 0 - 3 bar
5	VALVE FUNCTIONS: 5 = 2-way NC
2	COMMAND: 2 = 0-10 V DC 3 = 4-20 mA
2	OUTPUT SIGNAL: 2 = 0-10 V
0	CABLE LENGTH: 0 = without cable 2F = straight cable, 2 m 2R = right angle cable (90 degrees), 2 m 5F = straight cable, 5 m 5R = right angle cable (90 degrees), 5 m
APPLICATIONS The K8P proportional regulator can be used as a pilot valve to control the opening of high flow valves or to check the high flow pressure regulators proportionally (version with sub-base for the pressure remote reading). It enables proportional control of power in lifting systems and can be used with inert gas to maintain a constant pressure in pneumatic cylinders or expansion valve chambers. It has also been designed to maintain a constant pressure during the pulling power applied to the wires in winding machines, to modulate pressure during the smoothing process in woodworking machines or to adjust the opening of diaphragm valves.	

 2
 CONTROL

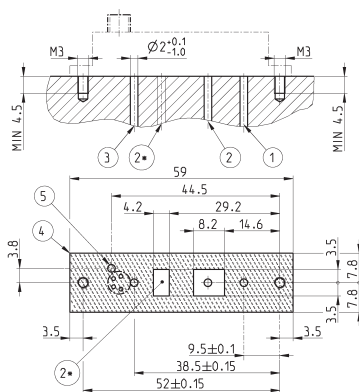
Interface for single use without sub-base

DRAWING LEGEND

	Notes
1 = Supply	Pneumatic connection
2 = Outlet	Pneumatic connection
2* = area for possible positioning of outlet port 2	Do not exceed the indicated outline
3 = Exhaust	Pneumatic connection
4 = OUTLET DIMENSION	
5 = VENT PORT FOR IP65	Optional when a OR seal is mounted

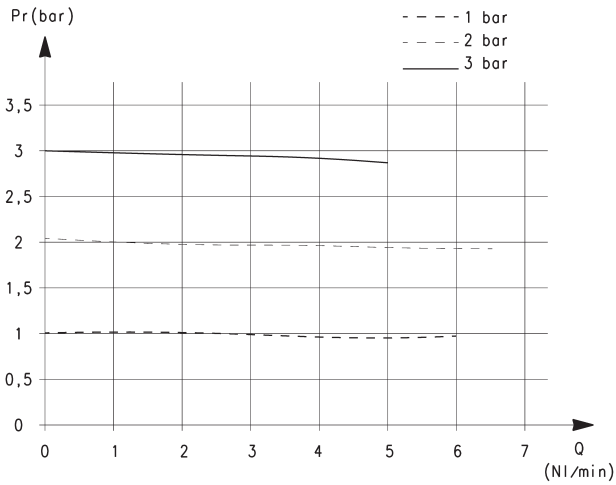
FLOW DIAGRAMS



Pr = Outlet pressure (bar)*
Q = Flow (NI/min)*

* = Inlet pressure 4 bar

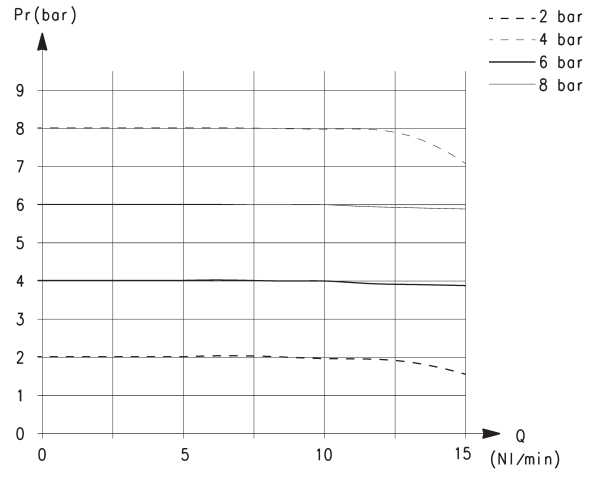

Pr = Outlet pressure (bar)*
Q = Flow (NI/min)*

* = Inlet pressure 10 bar

Series K8P electronic proportional micro regulator - dimensions

MALE CONNECTOR M8 4 POLES
Pin 1: +24 V DC (Power supply)
Pin 2: Command analogical signal 0-10 V DC or 4-20 mA
Pin 3: 0 V (Ground) common also for the command signal
Pin 4: Output analogical signal (according to the regulated pressure)



5 red LED
6 green LED

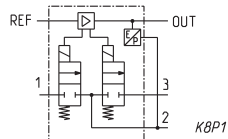
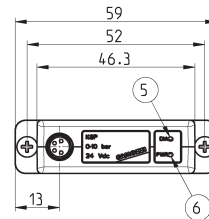
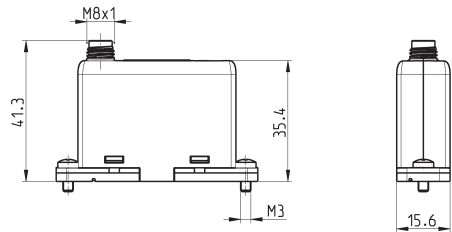

Mod.

K8P-0-D5*2-0	* according to the type of command desired, insert: 2 (0-10 V DC) or 3 (4-20 mA)
K8P-0-E5*2-0	* according to the type of command desired, insert: 2 (0-10 V DC) or 3 (4-20 mA)
K8P-L-E5*2-0	* according to the type of command desired, insert: 2 (0-10 V DC) or 3 (4-20 mA)
K8P-L-D5*2-0	* according to the type of command desired, insert: 2 (0-10 V DC) or 3 (4-20 mA)
K8P-S-D5*2-0	* according to the type of command desired, insert: 2 (0-10 V DC) or 3 (4-20 mA)
K8P-S-E5*2-0	* according to the type of command desired, insert: 2 (0-10 V DC) or 3 (4-20 mA)
K8P-T-D5*2-0	* according to the type of command desired, insert: 2 (0-10 V DC) or 3 (4-20 mA)
K8P-T-E5*2-0	* according to the type of command desired, insert: 2 (0-10 V DC) or 3 (4-20 mA)

Standard Sub-base

Note: the use of a silencer on the exhaust is recommended. *

* Mod. 2939 4

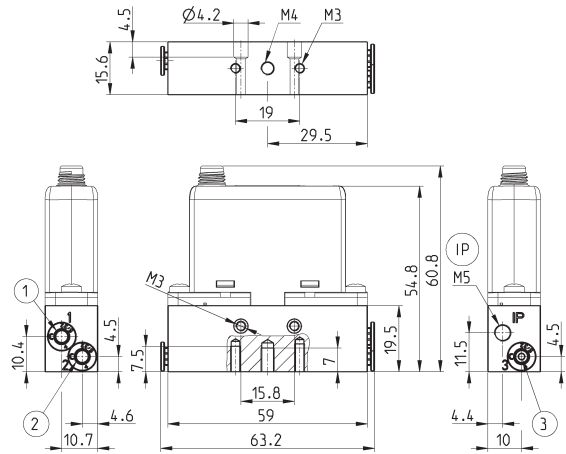

1 = Power supply
2 = Outlet
3 = Exhaust

IP = IP65 connection

Mod.
K8P-AS

Light Sub-base

Note: the use of a silencer on the exhaust is recommended. *

* Mod. 2931 M5, 2938 M5, 2901 M5

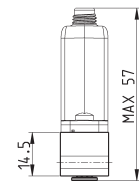
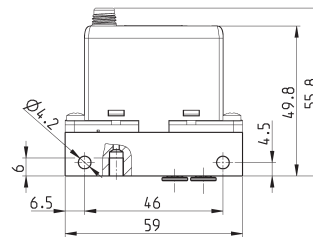
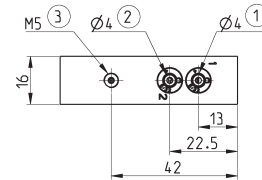

1 = Power supply
2 = Outlet
3 = Exhaust

Mod.
K8P-AL

Light Sub-base for the pressure remote reading

Note: the use of a silencer on the exhaust is recommended. *

* Mod. 2931 M5, 2938 M5, 2901 M5

In the version Light sub-base for the pressure remote reading it is also possible to use the fixing bracket B2-E531 (see page 5/2.05.15).

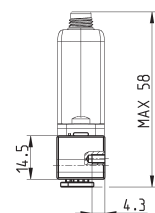
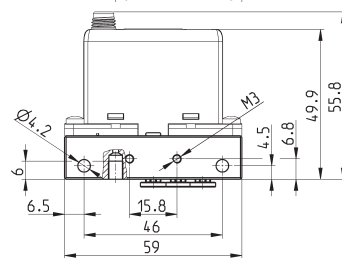
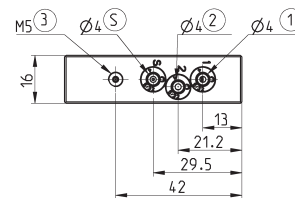

1 = Power supply
2 = Outlet
3 = Exhaust

S = remote-mounted sensor

Mod.
K8P-AT

Mounting bracket for DIN rail

DIN EN 50022 (7,5mm x 35mm - width 1)



Supplied with:
1x plate
1x screw M4x6 UNI 5931

Note: this accessory cannot be used with the Light sub-base version.

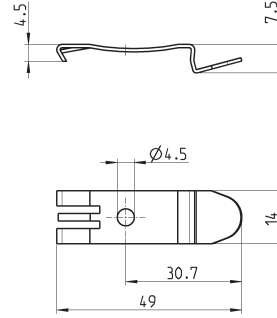

Mod.
PCF-K8P

Bracket for horizontal mounting, for standard sub-base

Supplied with:
1x mounting bracket
2x screws M3x8 UNI 5931

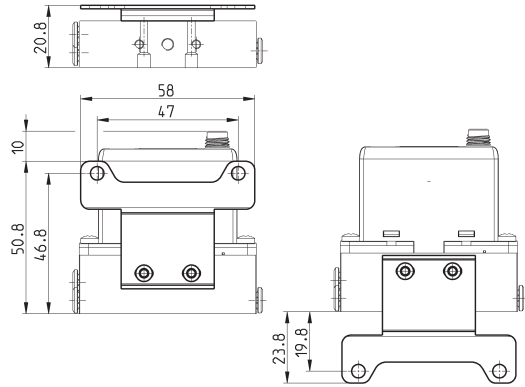

Mod.
K8P-B1

Circular M8 4-pole connectors, Female

With PU sheathing, non shielded cable.
Protection class: IP65

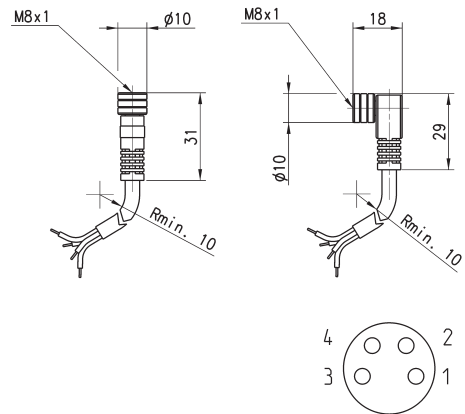

Mod.	Type of connector	Cable length (m)
CS-DF04EG-E200	straight	2
CS-DF04EG-E500	straight	5
CS-DR04EG-E200	right angle (90 degrees)	2
CS-DR04EG-E500	right angle (90 degrees)	5