

RE1

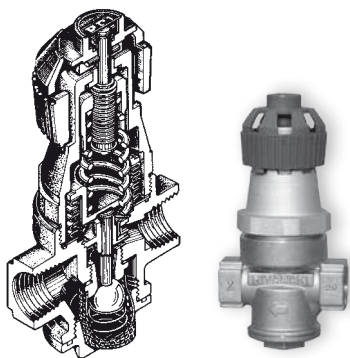

RE2

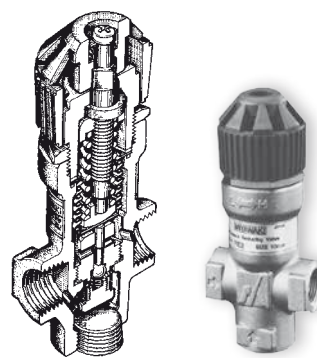

Capacity Charts RE1, RE1-4

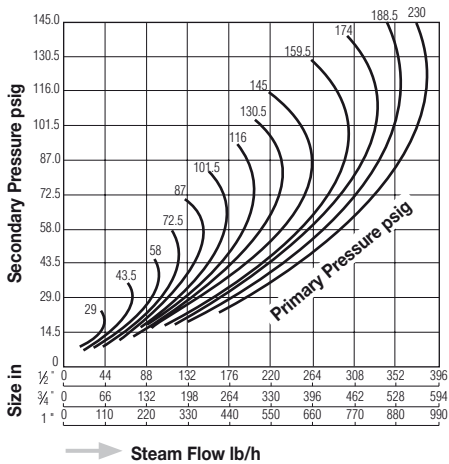
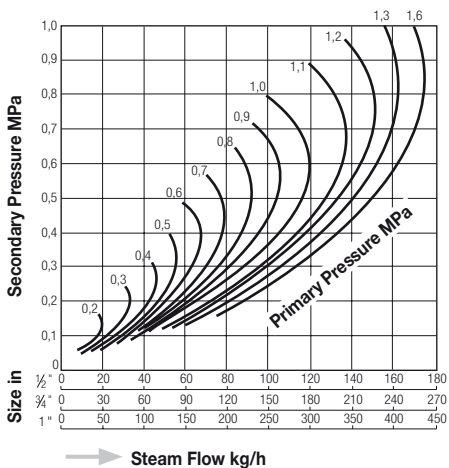

Capacity Charts RE1-2

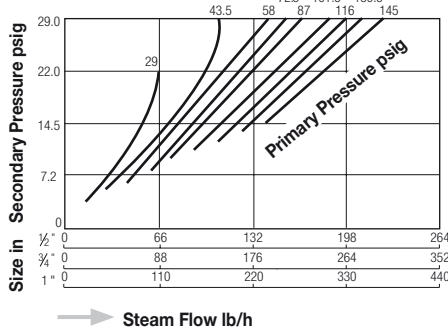
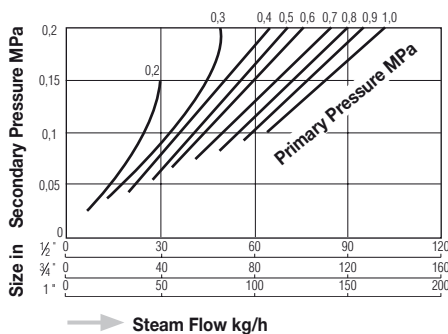

Capacity Charts RE2

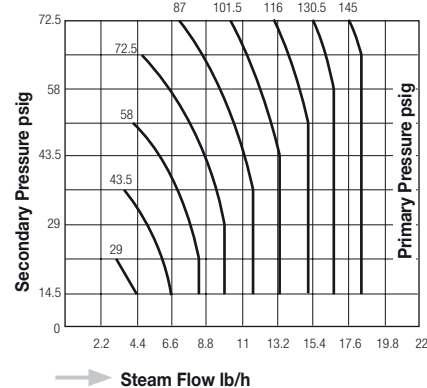
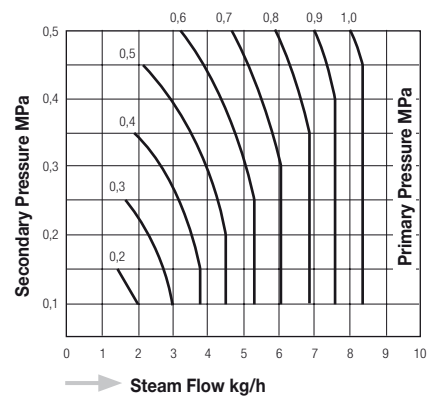

Dimensions RE1

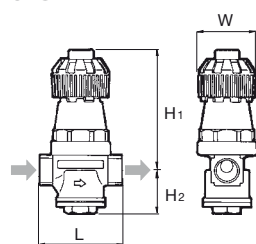

Dimensions RE2

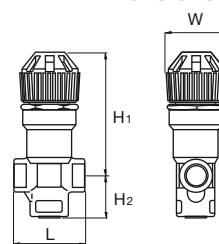

Model	Connection	Size (in)	Operating Pressure (Primary)		Secondary Pressure		Max. Red. Pressure Ratio	Max. Operating Temperature		Dimensions (mm)				Dimensions (in)				Body Material	Weight	
			MPa	psig	MPa	psig		°C	°F	L	H1	H2	W	L	H1	H2	W		kg	lb
RE1	Screwed Rc, NPT	1/2"	0.2 - 1.6	29 - 230	0.05 - 1.0	7.2 - 145	10 : 1	204	399	80	137	46	65	3.2	5.4	1.8	2.6	1.4	3.1	
		90								137	46	3.5		5.4	1.8	1.6		3.5		
		105								144	58	4.1		5.7	2.3	1.9		4.2		
RE1-4		Screwed Rc, NPT	1/2"	0.2 - 1.0	29 - 145	0.05 - 0.4	7.2 - 58	10 : 1	204	399	80	137	46	65	3.2	5.4	1.8	2.6	1.4	3.1
			90								137	46	3.5		5.4	1.8	1.6		3.5	
			105								144	58	4.1		5.7	2.3	1.9		4.2	
RE1-2	Screwed Rc, NPT	1/2"	0.2 - 1.0	29 - 145	0.02 - 0.2	2.9 - 29	10 : 1	204	399	80	137	46	65	3.2	5.4	1.8	2.6	1.4	3.1	
		90								137	46	3.5		5.4	1.8	1.6		3.5		
		105								144	58	4.1		5.7	2.3	1.9		4.2		
RE2	Screwed Rc, NPT	3/8"	0.2 - 1.0	29 - 145	0.1 - 0.5	14 - 72	10 : 1	184	363	50	89	31	43	2.0	3.5	1.2	1.7	0.56	1.2	