

NR

FREELY PROGRAMMABLE ROTARY TABLES | NR ROTARY RING TABLE



All NR rings allow customer-specific drive motors to be connected

NR ROTARY RING TABLE: FLEXIBLE IN EVERY RESPECT

WHEN IT'S GOT TO BE EXACT

We manufacture high-precision plates from AlMg4.5Mn (also available anodised on request), as well as steel plates (also available chemically nickel-plated on request), as per your drawings. With test protocol – everything from a single source.



OR RATHER A HEAVY DUTY ROTARY TABLE?

Our CR heavy duty rotary table range is available for heavy loads.



Production of technical braidings at Bossert + Kast: the NR 750 rotary ring table is used as a gear-driven turntable: large bearing, integrated gears, large central opening.



Rotary ring table with very large central opening, extremely flat design and high parts accuracy. The ring-shaped design allows extra free design space. The rotating aluminium ring can be adjusted to your specifications in terms of diameter and thickness.

ADVANTAGES

- Ring-shaped rotary table with very large central opening
- High level of parts accuracy through locking on the outer edges
- Highly dynamic with smooth acceleration
- Flat, compact design – compatible with our tried and tested machines
- Four sizes
- Absolute measuring system
- Simplest control system, identical to our rotary tables
- Excellent price-performance
- Appealing design

NR 750Z

TECHNICAL DATA

Dial ring inside diameter:	Max. 490 mm
Dial ring outside diameter:	Min. 750 mm
Surface of the dial ring:	Anodised
Direction of rotation:	Clockwise - counter clockwise or reciprocating
Cycle rate:	Up to approx. 120 cycles/min, depending on mass moment of inertia and angle of rotation
Voltage:	400...480 V \pm 10%, 42...62 Hz special voltages upon request
Weight:	Approx. 230 kg
Mounting position:	Dial ring horizontal
Indexing precision (arcsec):	$\pm 18''$
Indexing precision in radian measurement:	± 0.033 mm (at \varnothing 750 mm)
Max. axial run-out of ring:	* 0.05 mm (at \varnothing 750 mm)
Max. concentricity:	* 0.03 mm
Max. parallelism of rotating plate surface to bottom housing surface:	* 0.05 mm (at \varnothing 750 mm)
Max. outer diameter:	1500 mm (or following consultation)

DRIVING DATA**

i_{Total}	90 / or 180
$M_{Motor\ max}$	30 Nm
$M_{Brake\ max}$	15 Nm
$n_{Motor\ max}$	2000 rpm

* Attention! In order to reach the above axial and radial run-out tolerances, please ensure that the axial run-out of the mounting plate is accurate.

** It is possible to fit popular alternative motors from various manufacturers. We are happy to advise you if you require any further information.

TIMING DIAGRAM

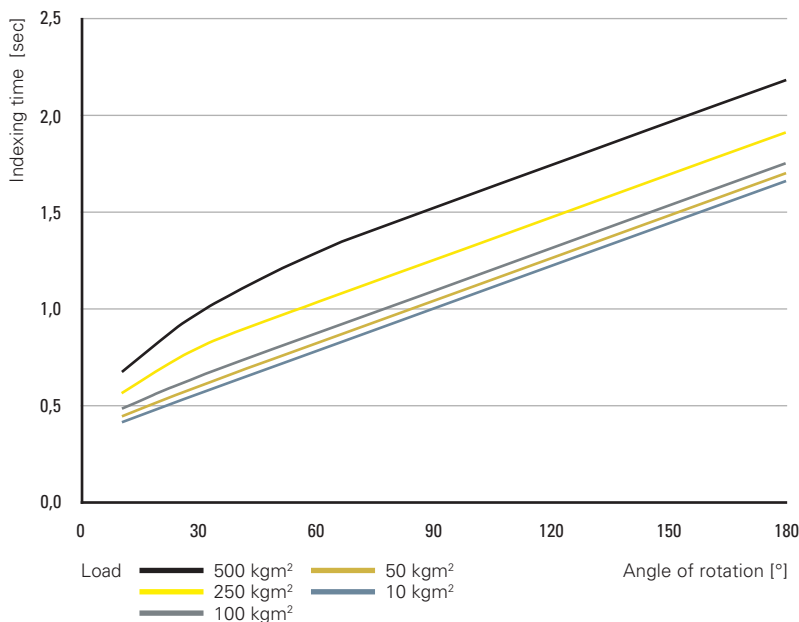

Please add the mass moment of inertia of your fixtures and parts to the mass moment of inertia of the rotary ring. Standard dimensions of the rotary ring (I/D = \varnothing 490 mm, O/D = \varnothing 750 mm, thickness = 20 mm, material Al) $J = 1.4$ kgm²

LOAD DATA

Vertical force on the locked ring

F_N : 3500 N

Perm. tilting moment acting on the locked ring

M_K : 750 Nm

Perm. tangential moment acting on the locked ring

T_R : 2180 Nm

Perm. radial force acting on the locked ring

F_R : 7000 N

max. central load on the ring at $M_K = 0$ Nm and $F_R = 0$ N on demand. Combined loads only after inspection by WEISS.

DIMENSIONS

The shown position of the rotating ring corresponds to the home position (state of delivery). Additional indexing plates are not included in the standard delivery scope and are subject to an extra charge. They are calculated separately as per your details.

The drive can be swung outside or inside

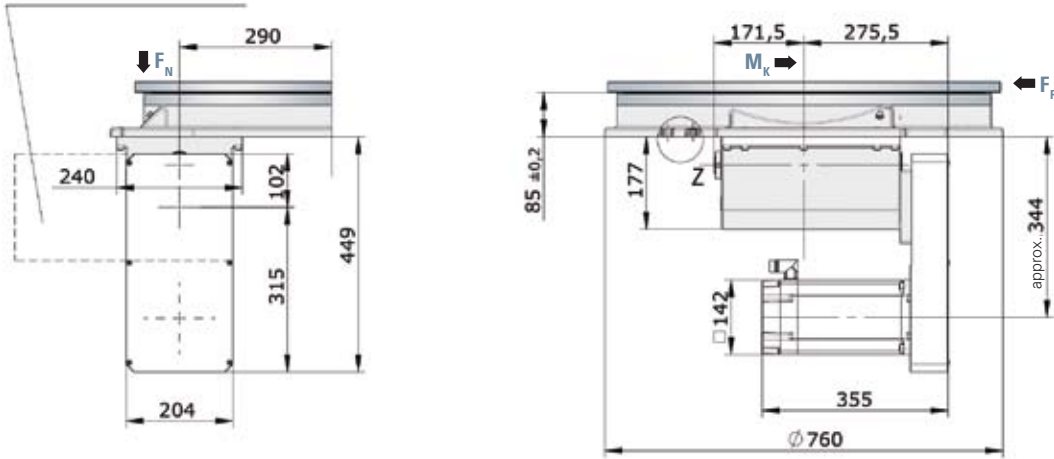

① Auxiliary holes for production: based on the plate diameter; 3x120°

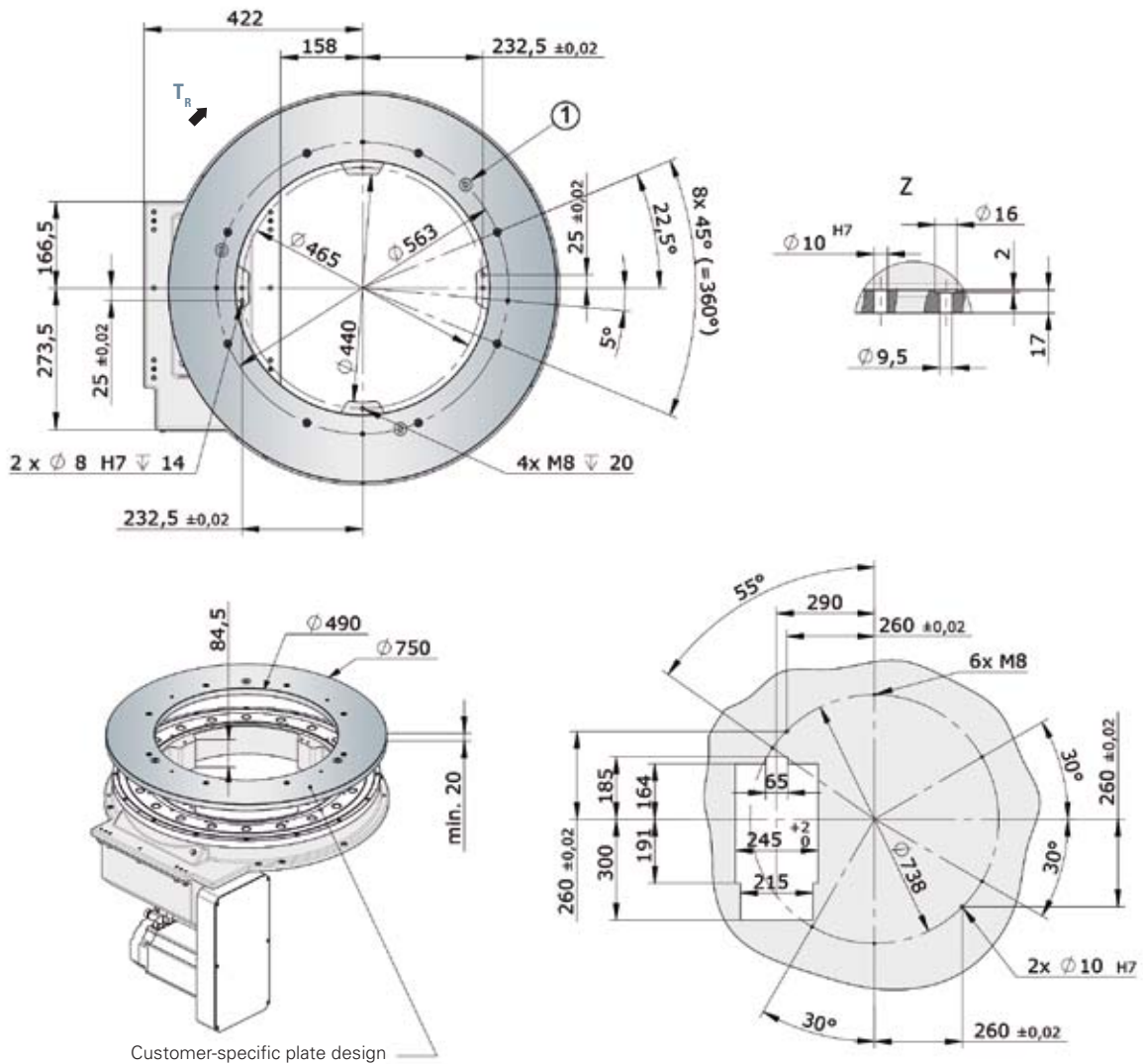

Customer-specific plate design

NR 1100Z

TECHNICAL DATA

Dial ring inside diameter:	Max. 800 mm
Dial ring outside diameter:	Min. 1100 mm
Surface of the dial ring:	Anodised
Direction of rotation:	Clockwise - counter clockwise or reciprocating
Cycle rate:	Up to approx. 120 cycles/min, depending on mass moment of inertia and angle of rotation
Voltage:	400...480 V \pm 10%, 42...62 Hz special voltages upon request
Weight:	Approx. 310 kg
Mounting position:	Dial ring horizontal
Indexing precision (arcsec):	$\pm 18''$
Indexing precision in radian measurement:	± 0.048 mm (at \varnothing 1100 mm)
Max. axial run-out of ring:	* 0.06 mm (at \varnothing 1100 mm)
Max. concentricity:	* 0.04 mm
Max. parallelism of rotating plate surface to bottom housing surface:	* 0.06 mm (at \varnothing 1100 mm)
Max. outer diameter:	2200 mm (or following consultation)

DRIVING DATA**

i_{Total}	88
$M_{Motor\ max}$	50 Nm
$M_{Brake\ max}$	32 Nm
$n_{Motor\ max}$	2000 rpm

* Attention! In order to reach the above axial and radial run-out tolerances, please ensure that the axial run-out of the mounting plate is accurate.

** It is possible to fit popular alternative motors from various manufacturers. We are happy to advise you if you require any further information.

TIMING DIAGRAM

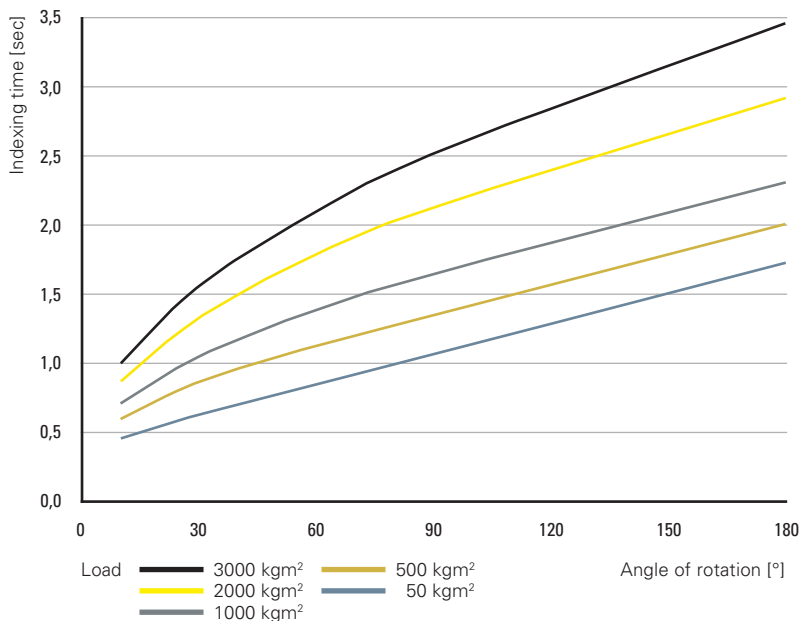

Please add the mass moment of inertia of your fixtures and parts to the mass moment of inertia of the rotary ring. Standard dimensions of the rotary ring (I/D = \varnothing 800 mm, O/D = \varnothing 1100 mm, thickness = 25 mm, material Al) $J = 7$ kgm².

LOAD DATA

Vertical force on the locked ring

F_N : 6000 N

Perm. tilting moment acting on the locked ring

M_K : 2500 Nm

Perm. tangential moment acting on the locked ring

T_R : 3500 Nm

Perm. radial force acting on the locked ring

F_R : 12000 N

max. central load on the ring at $M_K = 0$ Nm and $F_R = 0$ N on demand. Combined loads only after inspection by WEISS.

DIMENSIONS

The shown position of the rotating ring corresponds to the home position (state of delivery). Additional indexing plates are not included in the standard delivery scope and are subject to an extra charge. They are calculated separately as per your details.

The drive can be swung outside or inside

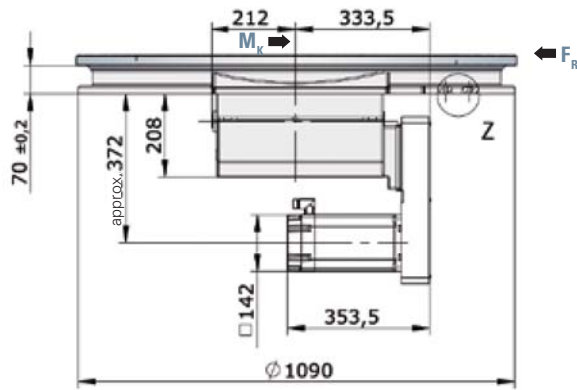
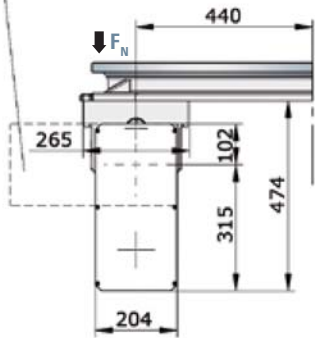

① Auxiliary holes for production: based on the plate diameter; 3x120°

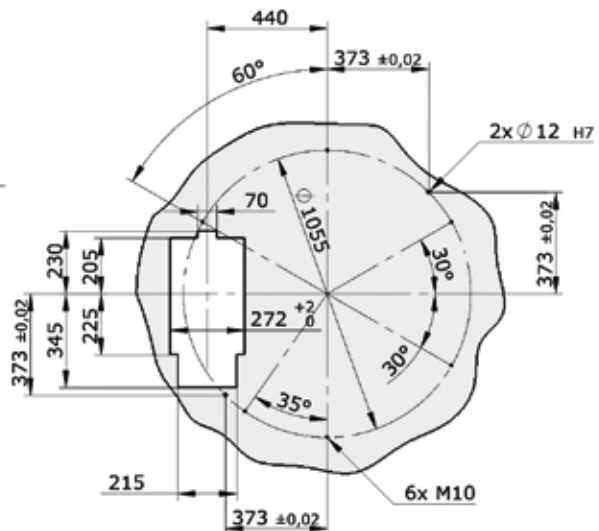
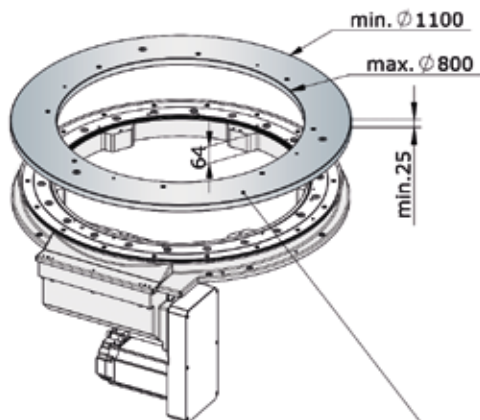
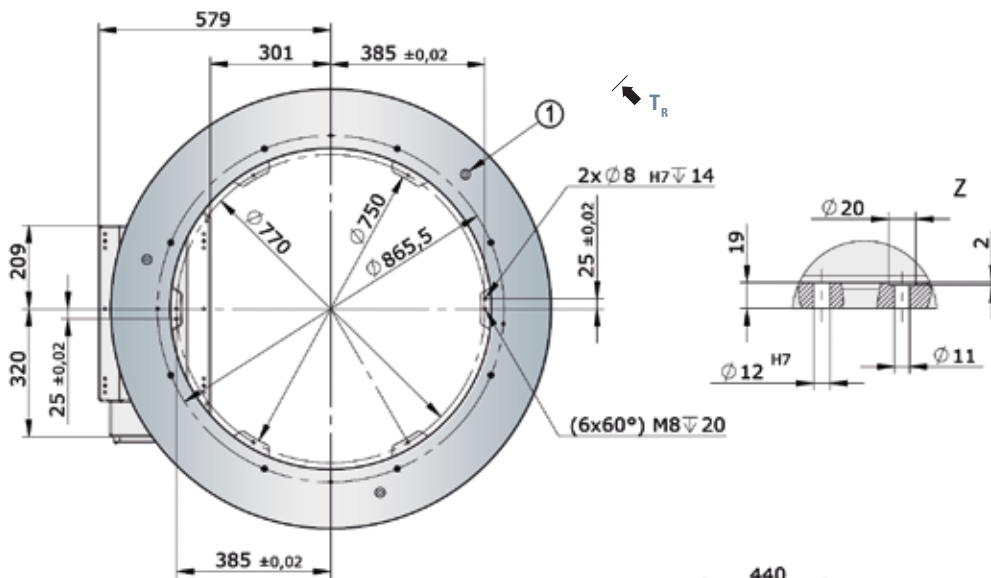

Customer-specific plate design (included in the scope of functions offered by the TR)
Do not drill through the plate in the min/max area.

NR 1500Z

TECHNICAL DATA

Dial ring inside diameter:	Max. 1135 mm
Dial ring outside diameter:	Min. 1500 mm
Surface of the dial ring:	Anodised
Direction of rotation:	Clockwise - counter clockwise or reciprocating
Cycle rate:	Up to approx. 120 cycles/min, depending on mass moment of inertia and angle of rotation
Voltage:	400...480 V \pm 10%, 42...62 Hz special voltages upon request
Weight:	Approx. 400 kg
Mounting position:	Dial ring horizontal
Indexing precision (arcsec):	\pm 15"
Indexing precision in radian measurement:	\pm 0.055 mm (at \varnothing 1500 mm)
Max. axial run-out of ring:	* 0.08 mm (at \varnothing 1500 mm)
Max. concentricity:	* 0.04 mm
Max. parallelism of rotating plate surface to bottom housing surface:	* 0.08 mm (at \varnothing 1500 mm)
Max. outer diameter:	3000 mm (or following consultation)

DRIVING DATA**

i_{Total}	112
$M_{Motor\ max}$	55 Nm
$M_{Brake\ max}$	32 Nm
$n_{Motor\ max}$	2000 rpm

* Attention! In order to reach the above axial and radial run-out tolerances, please ensure that the axial run-out of the mounting plate is accurate.

** It is possible to fit popular alternative motors from various manufacturers. We are happy to advise you if you require any further information.

TIMING DIAGRAM

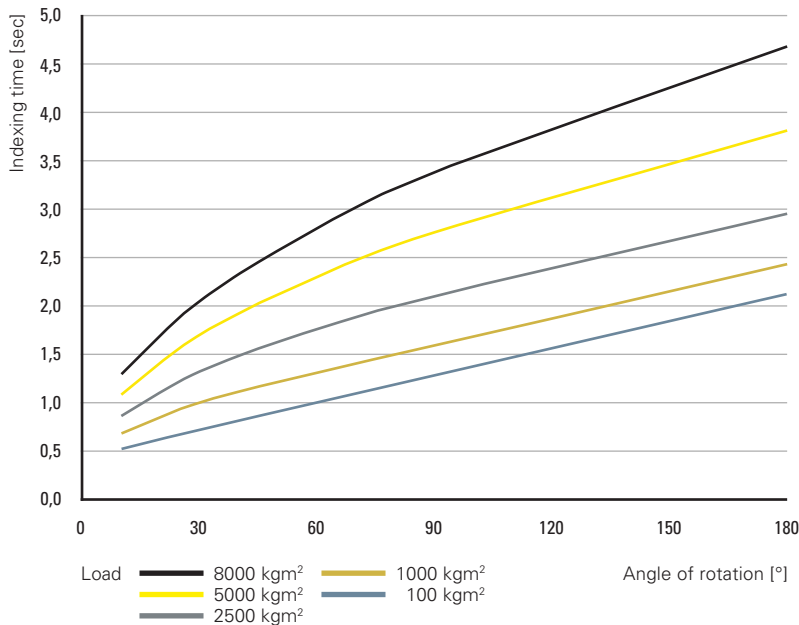

Please add the mass moment of inertia of your fixtures and parts to the mass moment of inertia of the rotary ring. Standard dimensions of the rotary ring (I/D = \varnothing 1135 mm, O/D = \varnothing 1500 mm, thickness = 25 mm, material Al) $J = 22.5 \text{ kgm}^2$

LOAD DATA (for rotary ring)

Vertical force on the locked ring

F_N : 8000 N

Perm. tilting moment acting on the locked ring

M_K : 3200 Nm

Perm. tangential moment acting on the locked ring

T_R : 4500 Nm

Perm. radial force acting on the locked ring

F_R : 16000 N

Max. central load on the ring at $M_k = 0 \text{ Nm}$ and $F_R = 0 \text{ N}$ on demand. Combined loads only after inspection by WEISS.

DIMENSIONS

The shown position of the rotating ring corresponds to the home position (state of delivery). Additional indexing plates are not included in the standard delivery scope and are subject to an extra charge. They are calculated separately as per your details.

The drive can be swung outside or inside

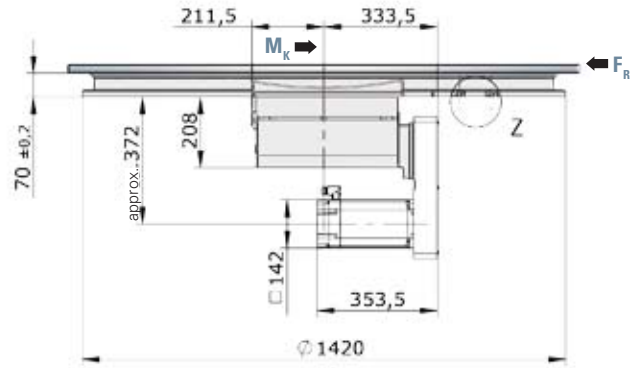
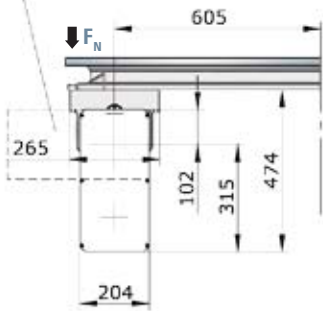

① Auxiliary holes for production:
based on the plate diameter; 3x120°

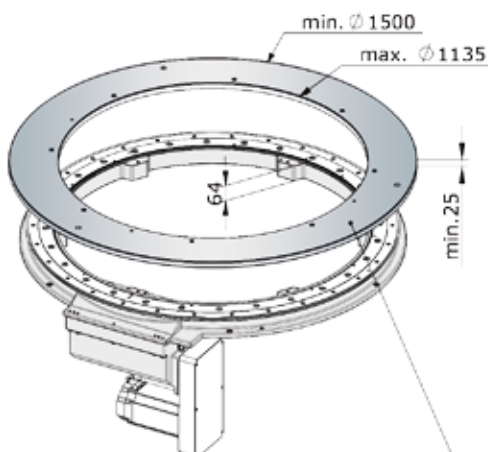
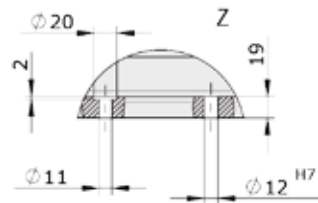
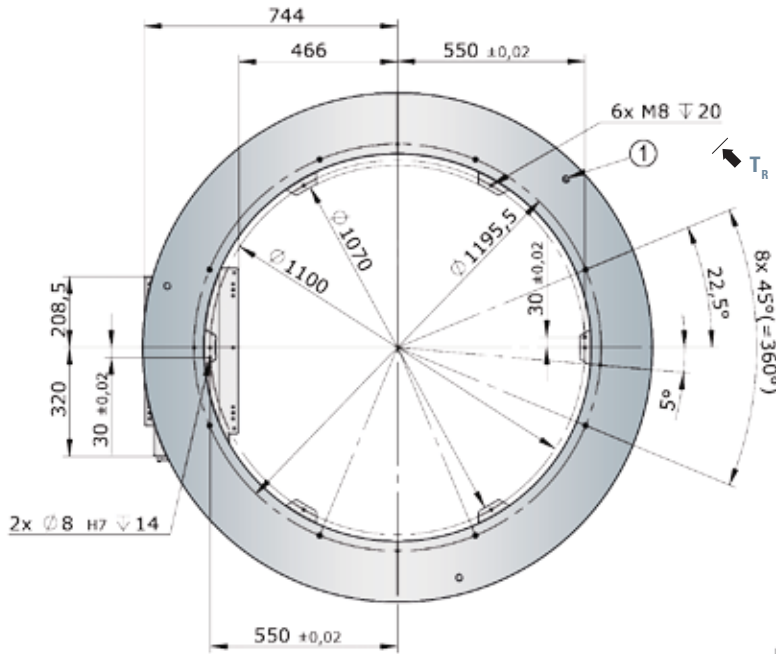

Customer-specific plate design
(included in the scope of functions offered by the TR)
Do not drill through the plate in the min/max area.

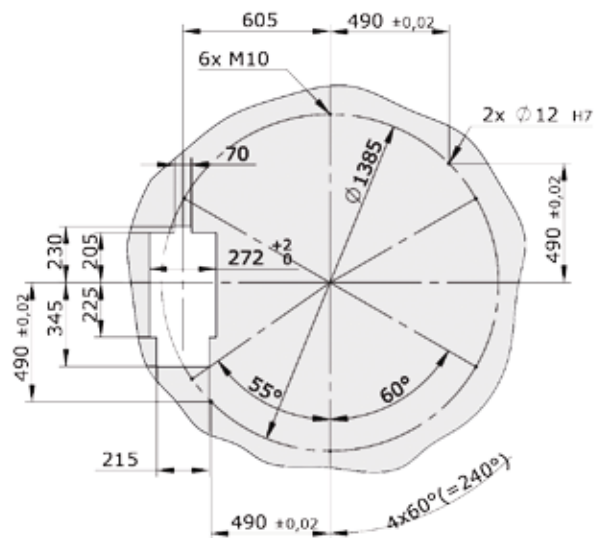

NR 2200Z

TECHNICAL DATA

Dial ring inside diameter:	Max. 1135 mm
Dial ring outside diameter:	Min. 1500 mm
Surface of the dial ring:	Anodised
Direction of rotation:	Clockwise - counter clockwise or reciprocating
Cycle rate:	Up to approx. 120 cycles/min, depending on mass moment of inertia and angle of rotation
Voltage:	400...480 V \pm 10%, 42...62 Hz special voltages upon request
Weight:	Approx. 400 kg
Mounting position:	Dial ring horizontal
Indexing precision (arcsec):	\pm 15"
Indexing precision in radian measurement:	\pm 0.055 mm (at \varnothing 1500 mm)
Max. axial run-out of ring:	* 0.08 mm (at \varnothing 1500 mm)
Max. concentricity:	* 0.04 mm
Max. parallelism of rotating plate surface to bottom housing surface:	* 0.08 mm (at \varnothing 1500 mm)
Max. outer diameter:	3000 mm (or following consultation)

DRIVING DATA**

i_{Total}	1220
$M_{Motor\ max}$	80 Nm
$M_{Brake\ max}$	32 Nm
$n_{Motor\ max}$	2000 rpm

* Attention! In order to reach the above axial and radial run-out tolerances, please ensure that the axial run-out of the mounting plate is accurate.

** It is possible to fit popular alternative motors from various manufacturers. We are happy to advise you if you require any further information.

TIMING DIAGRAM

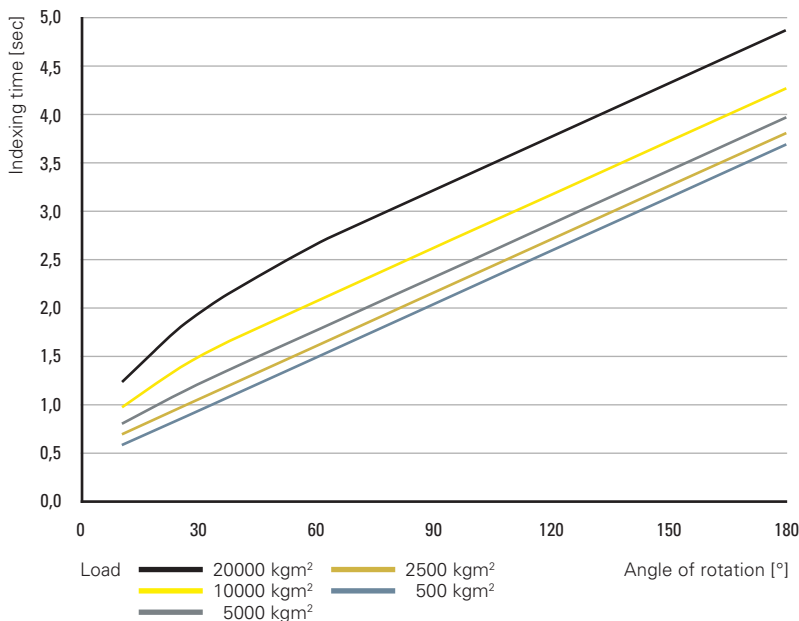

Please add the mass moment of inertia of your fixtures and parts to the mass moment of inertia of the rotary ring.
For the standard ring (I/D = 1135 mm, O/D = 2200 mm, thickness = 30 mm, material Al) $J = 22.5 \text{ kgm}^2$

LOAD DATA (for rotary ring)

Vertical force on the locked ring

F_N : 15000 N

Perm. tilting moment acting on the locked ring

M_K : 4500 Nm

Perm. tangential moment acting on the locked ring

T_R : 10000 Nm

Perm. radial force acting on the locked ring

F_R : 30000 N

Max. central load on the ring at $M_K = 0 \text{ Nm}$ and $F_R = 0 \text{ N}$ on demand. Combined loads only after inspection by WEISS.

DIMENSIONS

The shown position of the rotating ring corresponds to the home position (state of delivery). Additional indexing plates are not included in the standard delivery scope and are subject to an extra charge. They are calculated separately as per your details.

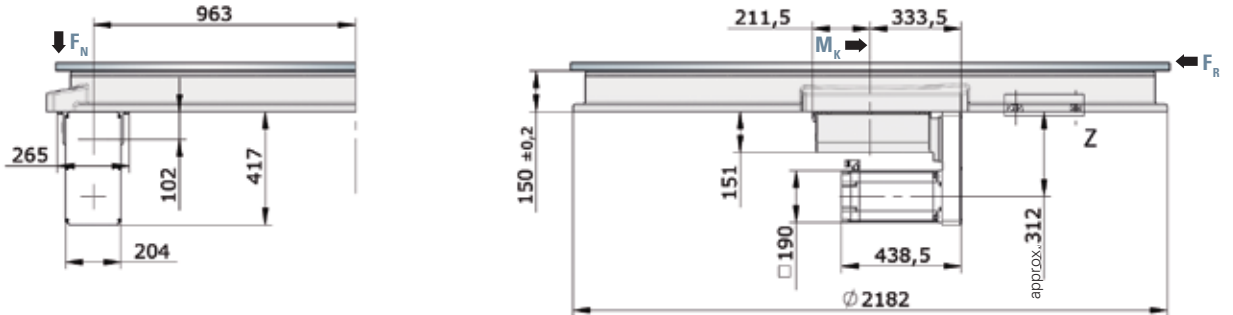

- ① Auxiliary holes for production: based on the plate diameter; 3x120°

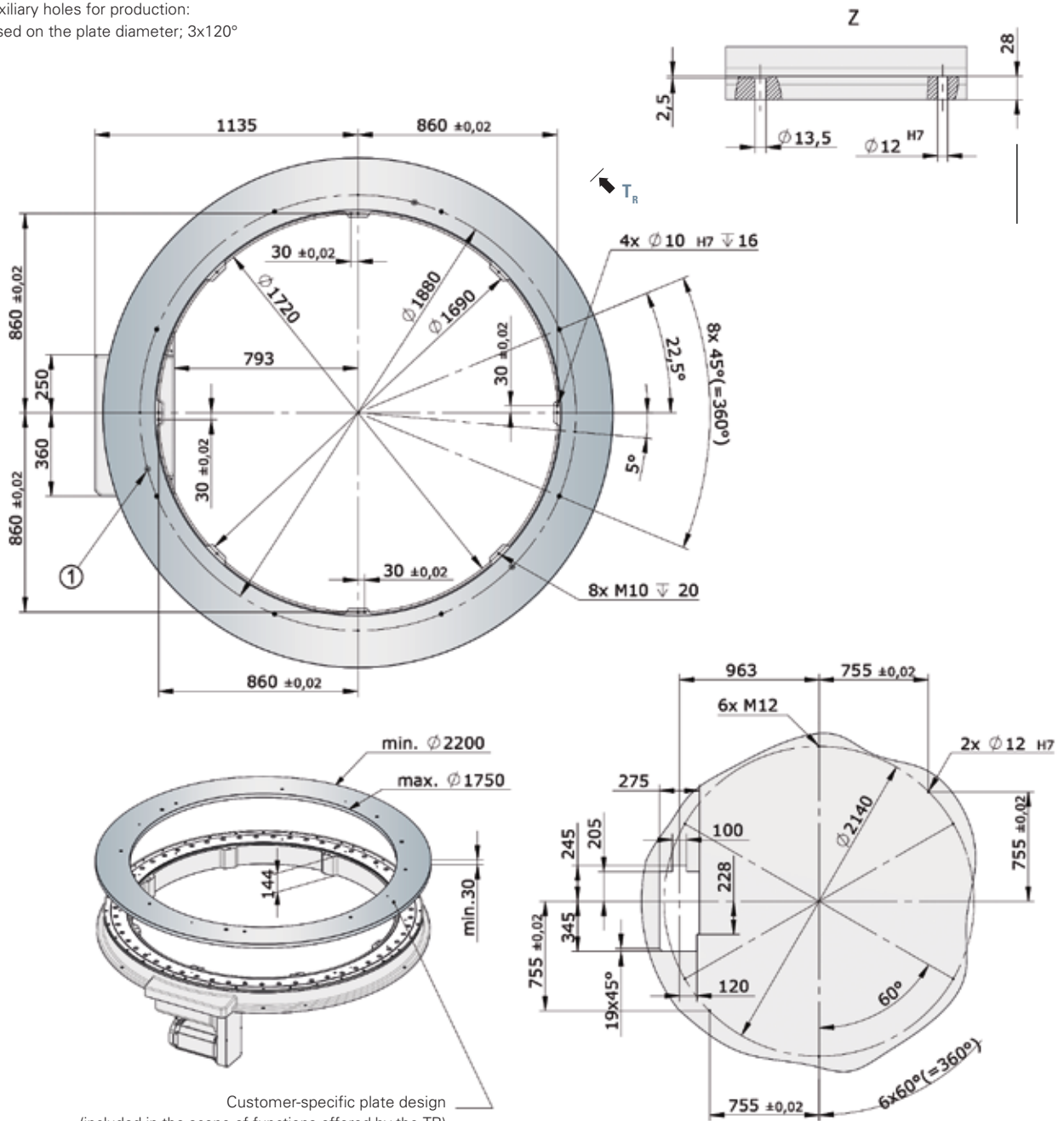

W.A.S./W.A.S. 2

WEISS APPLICATION SOFTWARE

The W.A.S. (WEISS Application Software) offers you easy access to the table drive options. The W.A.S. 2 software also offers quick and easy commissioning of entire multi-axis systems.

- Free language selection
- Easy access to axis parameters
- Diagnostic options, remote maintenance
- Inputs and outputs can be forced (e.g. for start-up)
- Software cams can be specified
- Error history



DESIGN AND CONNECTION

- Plug & play
- Pre-parameterised control package
- Perfectly matched components
- Outstanding flexibility with regard to cable length and interfaces

COMMUNICATION

- Digital I/O (24-V inputs and outputs)
- Profibus DP
- EtherNet/IP (Rockwell)
- PROFINET (W.A.S. 2 only)
- EtherCAT (W.A.S. 2 only)
- More available on request

SAFETY AND SERVICE

- Absolute measuring system
- Safe torque off function integrated
- Safe Motion on request
- Worldwide service
- Comprehensive safety and monitoring functions

Electrical data	NR 750Z	NR 1100Z	NR 1500Z	NR 2200Z
Main power voltage	400 up to 480 VAC ± 10%; 48 up to 62 Hz	3 x 400 VAC, up to 80 VAC ± 10%; 48 up to 62 Hz	3 x 400 VAC, up to 80 VAC ± 10%; 48 up to 62 Hz	3 x 400 VAC, up to 80 VAC ± 10%; 48 up to 62 Hz
Power voltage 24 V	24 VDC ± 5%; 2.5 A + Brake	24 VDC ± 5%; 5 A + Brake	24 VDC ± 5%; 5 A + Brake	24 VDC ± 5%; 5 A + Brake
Connection power max.	10 kVA	17 kVA	17 kVA	17 kVA
Installation dimensions W x H x D	70.5 x 375 x 236 mm	200 x 375 x 234 mm	200 x 375 x 234 mm	200 x 375 x 234 mm

ACP Multi circuit diagram (W.A.S. 2)

