

HP

HANDLING MODULES | HP PICK & PLACE

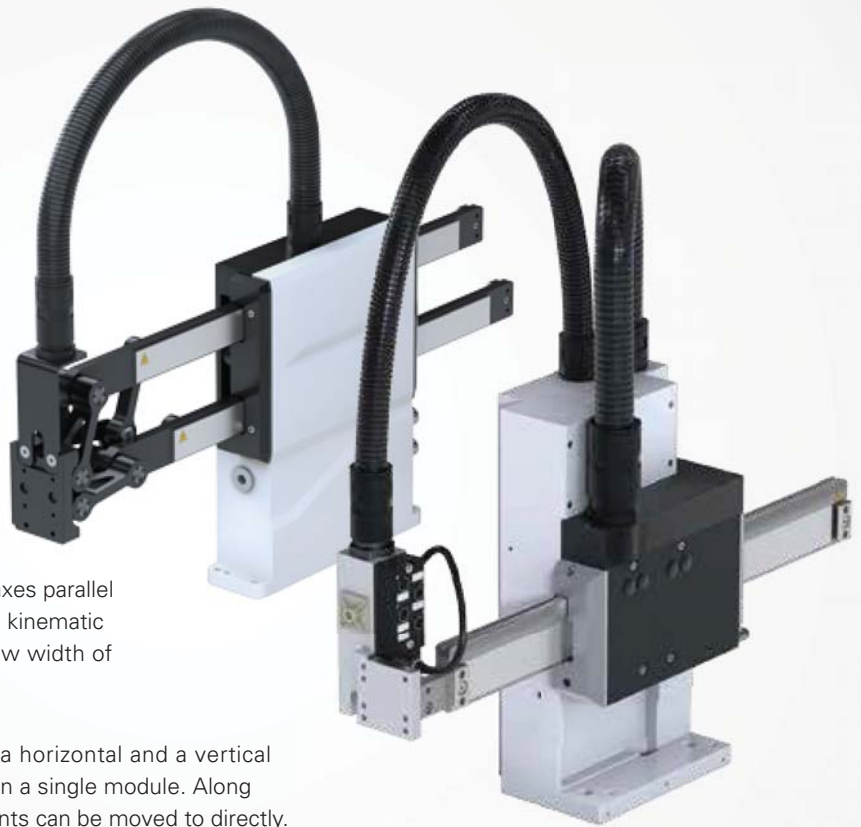

Pick & Place HP 70: two horizontal linear axes parallel on top of each other, connected through a kinematic unit. Because of the construction a narrow width of only 60mm is possible.

Pick & Place HP 140: a horizontal and a vertical linear axis integrated in a single module. Along these two axes all points can be moved to directly.

HP PICK & PLACE: THE DIRECT ALTERNATIVE

THE SOLUTION FOR CLEANROOMS

The HP 140T CL 6 Pick & Place has been designed for use in cleanrooms and is certified to air purity class 6 in line with ISO 14644-1.



WEISS APPLICATION SOFTWARE

Fast, convenient and secure commissioning using W.A.S. – WEISS Application Software: Simple control system, practical plain text.



W.A.S. handling
WEISS Application Software

Automated assembly system for electromechanical sensors from UBH Mechanical Engineering: eleven direct-drive Pick & Place units achieve positioning accuracy of 0.02 millimetres – at a cycle time of 1.5 seconds.

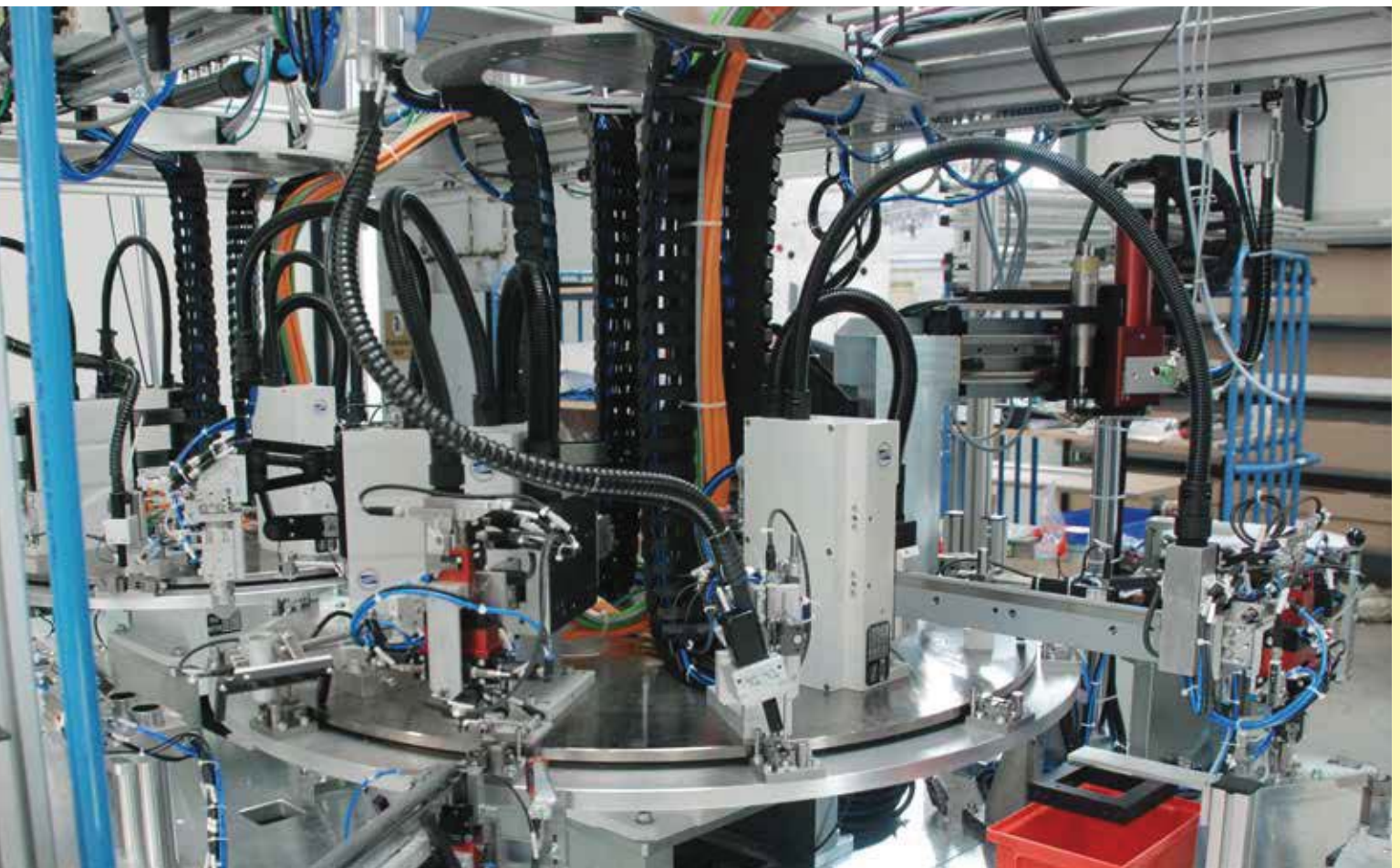

Whether HP 140 or HP 70: The Pick & Place from WEISS works with two linear axes and therefore profit from all advantages of a direct drive: rapid dynamic performance, free user-programmability, minimal wear and highest precision. The compact modules get reinforcement for place-saving applications with the extra slim HP 70. The HP overcomes limits of traditional pneumatic systems regarding variability, dynamic performance and efficiency.

ADVANTAGES

- Extremely high dynamic performance
- Ready-for-installation, holistic, customer-friendly complete solution (plug & play)
- Free user-programmability for changing tasks/processes
- Permanent feedback of position, process forces, speed (adjustable control circuit)
- Maintenance-free
- Significantly lower energy consumption, in particular in comparison with pneumatic systems
- Very compact and slim design, offering greater flexibility for integration and assembly of the machine
- W.A.S. – WEISS Application Software for simple commissioning
- Impressive price-performance
- Overload protection



HP 70T

LOAD DATA

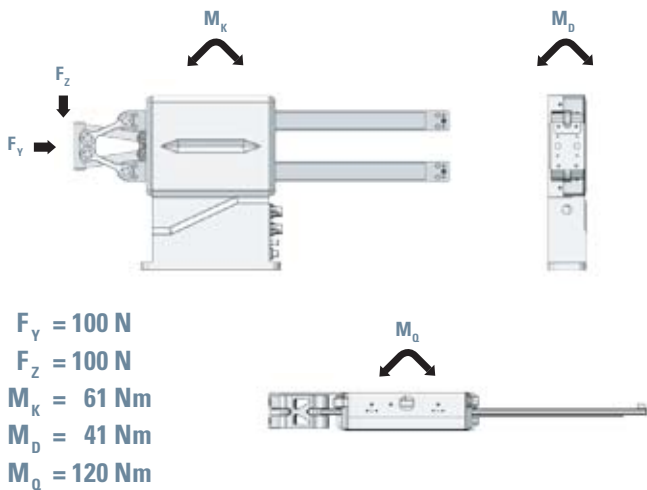

TECHNICAL DATA

Load capacity (kg):	1 kg (higher loading after consulting)
Vertical stroke:	70 mm freely programmable
Horizontal stroke:	125, 225, 325 mm freely programmable (see diagram below)
Positioning accuracy:	0.02 mm
Repeat accuracy:	0.01 mm
Max. acceleration:	40 m/s ²
Max. speed:	4 m/s
Nom. force (per motor):	65 N
Peak force (per motor):	180 N
Measuring system:	Sin-Cos 1Vpp, optional absolute
Installation position:	Horizontal (vertical after consulting)
Weight:	Approx. 9 kg

Please do not exceed the given forces – especially during pick or place operations. The accuracy is given for constant temperature and without outside forces.

MECHANICAL STROKE

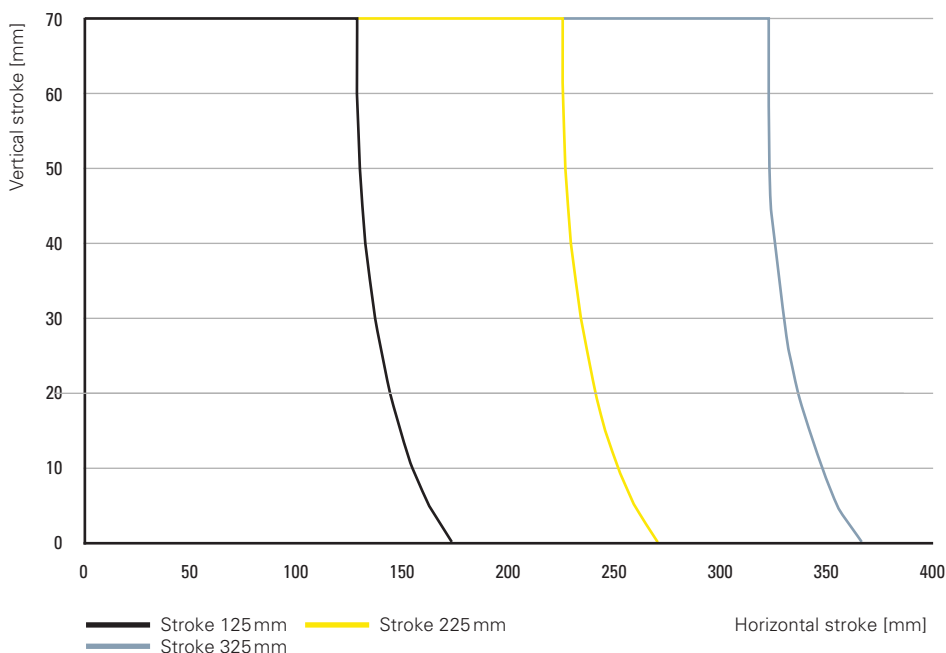

DIMENSIONS

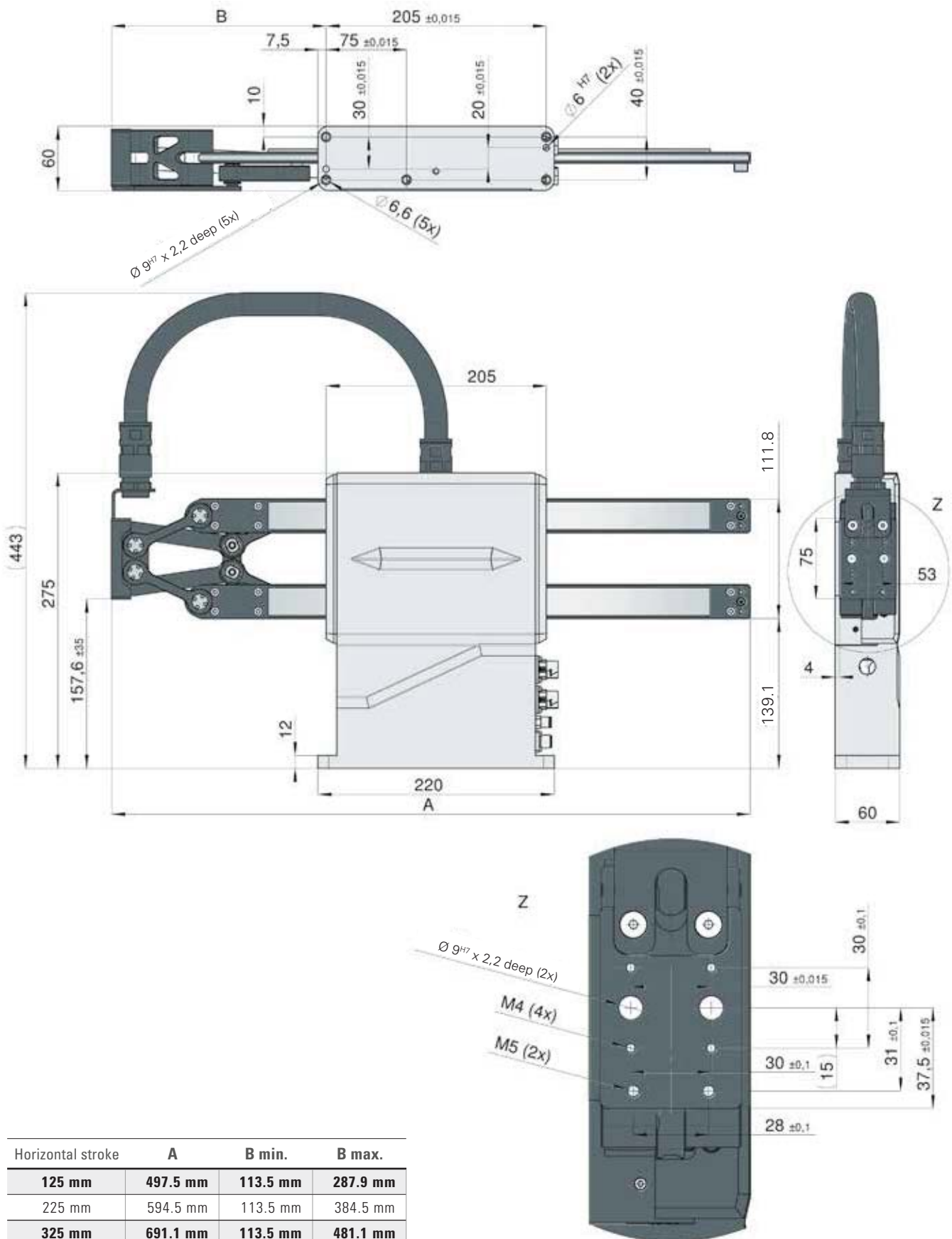

Horizontal stroke	A	B min.	B max.
125 mm	497.5 mm	113.5 mm	287.9 mm
225 mm	594.5 mm	113.5 mm	384.5 mm
325 mm	691.1 mm	113.5 mm	481.1 mm



HP 140T

TECHNICAL DATA

Max. load capacity:	3 kg
Vertical stroke:	65, 100, 150 mm (freely programmable)
Horizontal stroke:	160, 270, 300, 400 mm (freely programmable)
Positioning accuracy:	0.02 mm
Repeat accuracy:	0.01 mm
Max. acceleration:	40 m/s ²
Max. speed:	4 m/s
Installation position:	Horizontal
Weight:	11 - 18 kg

LOAD DATA

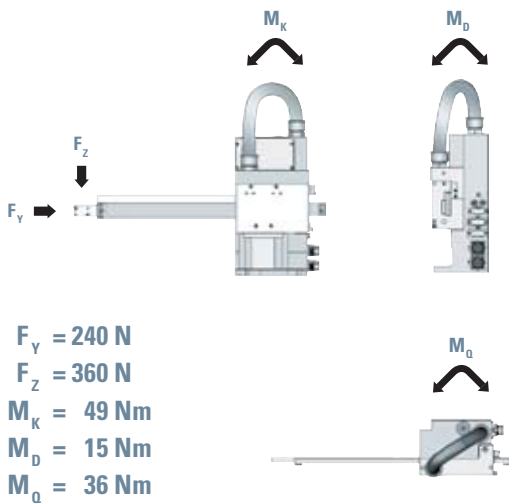

Please do not exceed the given forces – especially during pick or place operations. The accuracy is given for constant temperature and without outside forces.

CYCLE TIMES

Depending on the direction of travel, the complete cycle time can be calculated with the aid of the below example:

EXAMPLE:

Weight of workpiece	1 kg	Curved proportion of movement	10 mm
Vertical stroke	40 mm	Handshake control	20 ms
Horizontal stroke	120 mm		
Gripper delay time	50 ms		

Results for the full cycle from A to B and back:

$$t_{ABA} = 4 \times t_{\text{vertical}} + 2 \times t_{\text{horizontal}} + 2 \times t_{\text{delay time}} + t_{\text{Handshake}}$$

$$t_{ABA} = 4 \times 80 \text{ ms} + 2 \times 100 \text{ ms} + 2 \times 50 \text{ ms} + 20 \text{ ms}$$

$$t_{ABA} = 0.64 \text{ sec}$$



TIMING DIAGRAM To help calculate the exact cycle time, please forward your proposed sequence.

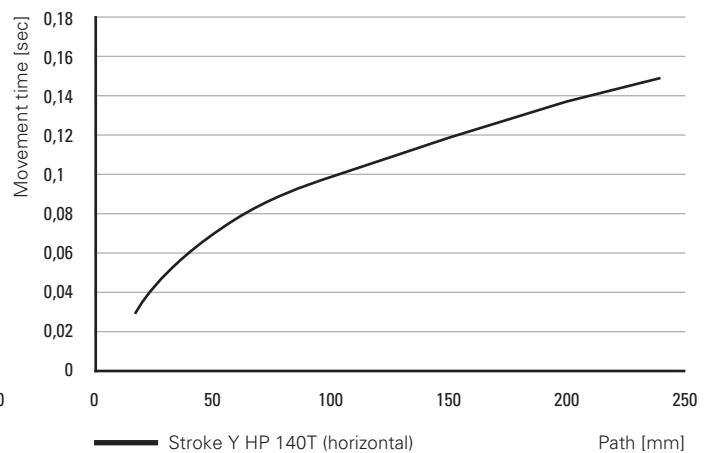
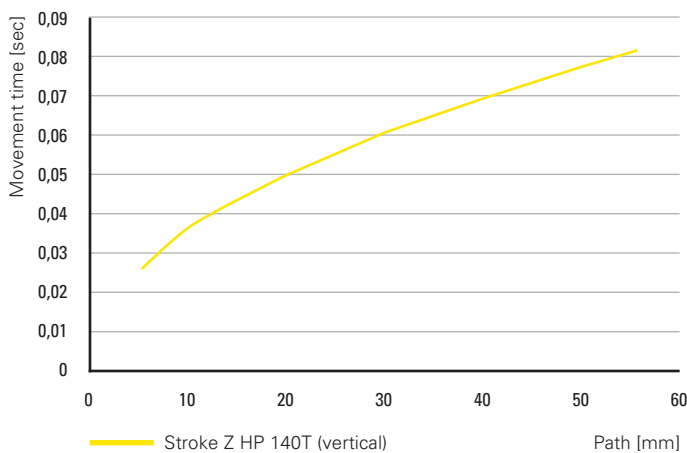

DIMENSIONS

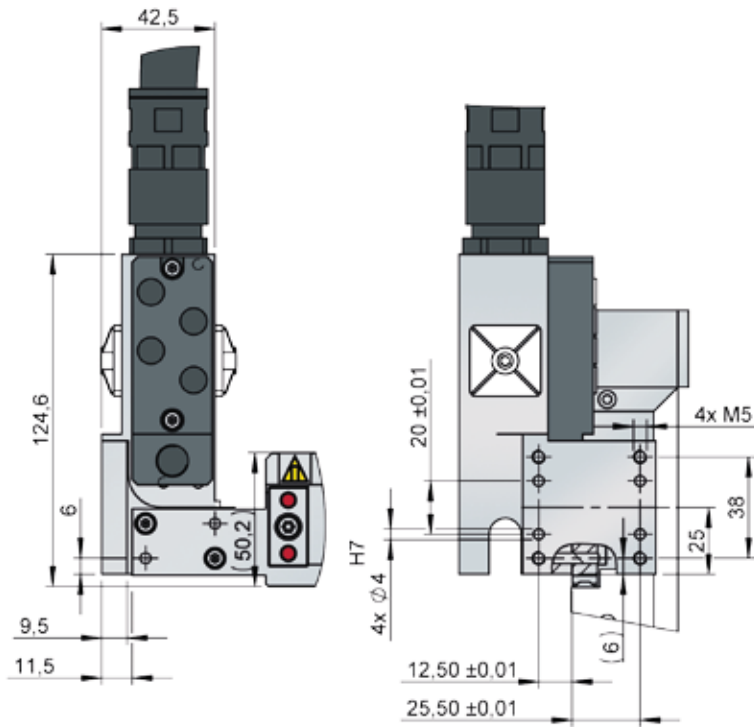

Vertical stroke	B	B ₁
65	478	296.5
100	581	371.5
150	653	471.5

Horizontal stroke	A	
160	402	*
270	512	*
300	542	*
400	642	*

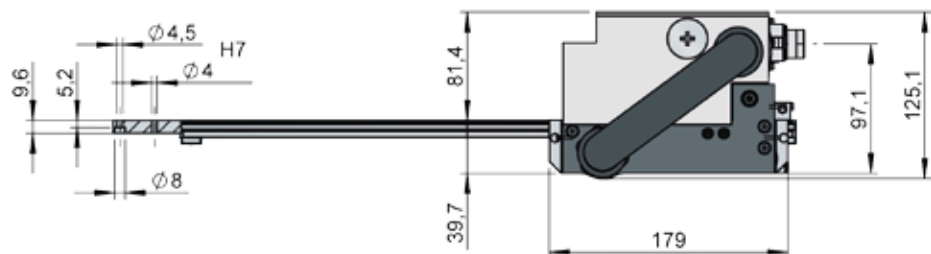
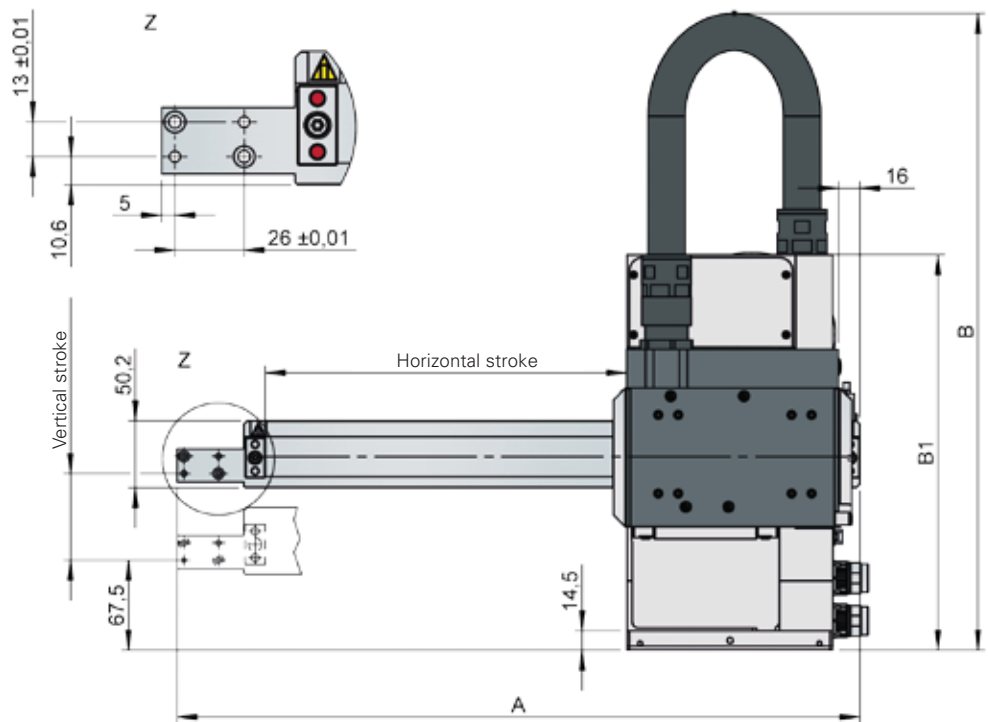
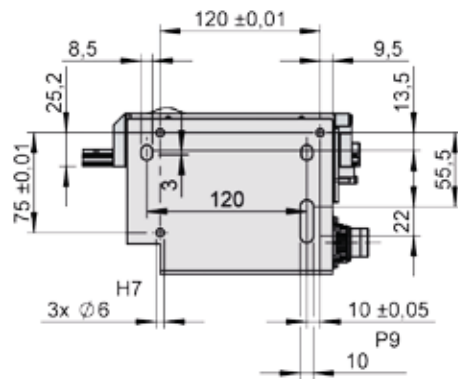

MACHINE DESIGN HANDLING

Fax to: +49 (0) 6281 5208-99 or just fill in the form online: www.weiss-international.com

Enquiry Attachment to order

Dear customer,
Thank you for your interest in our handling units. To ensure optimum design of the system for your specific requirements, please answer the following questions:

Single axis

Number of HN axes: _____



Stroke: _____ mm

Number of HG axes: _____



Stroke: _____ mm

Number of HL axes: _____



Stroke: _____ mm

- Without brake (hor.)
- Brake (vertical)
- 2 brakes (vertical)

Axis system

No. of HP handling units: _____



Y-Stroke: _____ mm

Z-Stroke: _____ mm

No. of linear gantries: _____



Y-Stroke: _____ mm

Z-Stroke: _____ mm

No. of cross-tables: _____



Y-Stroke: _____ mm

Z-Stroke: _____ mm

No. of 3-axis handling units: _____



X-Stroke: _____ mm

Y-Stroke: _____ mm

Z-Stroke: _____ mm

No. of gantry handling units: _____



X-Stroke: _____ mm

Y-Stroke: _____ mm

Z-Stroke: _____ mm

No. of 3-axis handling units: _____



X-Stroke: _____ mm

Y-Stroke: _____ mm

Z-Stroke: _____ mm

Cycle calculation

Payload: _____ (kg)

	Axis				Stroke	Time
	X	Y	U	A*		
1						
2						
3						
4						
5						
6						
7						
8						
9						
10						

* A = Rotary axis

Accessories

Measuring system incremental absolute (up to 1000mm stroke)

Lubrication automatic manual

Accessories for the HP

1 pneumatic valve 2 pneumatic valves

Tool connector with brake (HP 70)

For technical enquiries

Company: _____

Name: _____

Country: _____

Electrical components

WEISS control package

Amplifier, W.A.S. software

Cable lengths: 5m 10m 15m 20m 25m

Interface to customer PLC

Profibus-DP

Digital I/O

PROFINET (W.A.S. 2 only)

EtherCAT (W.A.S. 2 only)

Ethernet/IP (Rockwell)

Supply voltage

1 or 3 x 208 ... 230 V ~ 50/60 Hz

3 x 400 to 480 V ~ 50/60 Hz (larger installation dimensions)

Desired delivery date: _____

Phone: _____ Fax: _____

E-Mail: _____