

Differential Pressure

Nominal size DN	adm. differential pressure (backpressure) bar seating seal	
	PTFE	FKM / EPDM / NBR
10	40	16
15	40	16
20	40	16
25	40	16
32	40	16
40	35	16
50	27	16
65	20	16

Dimensions

angle seat body

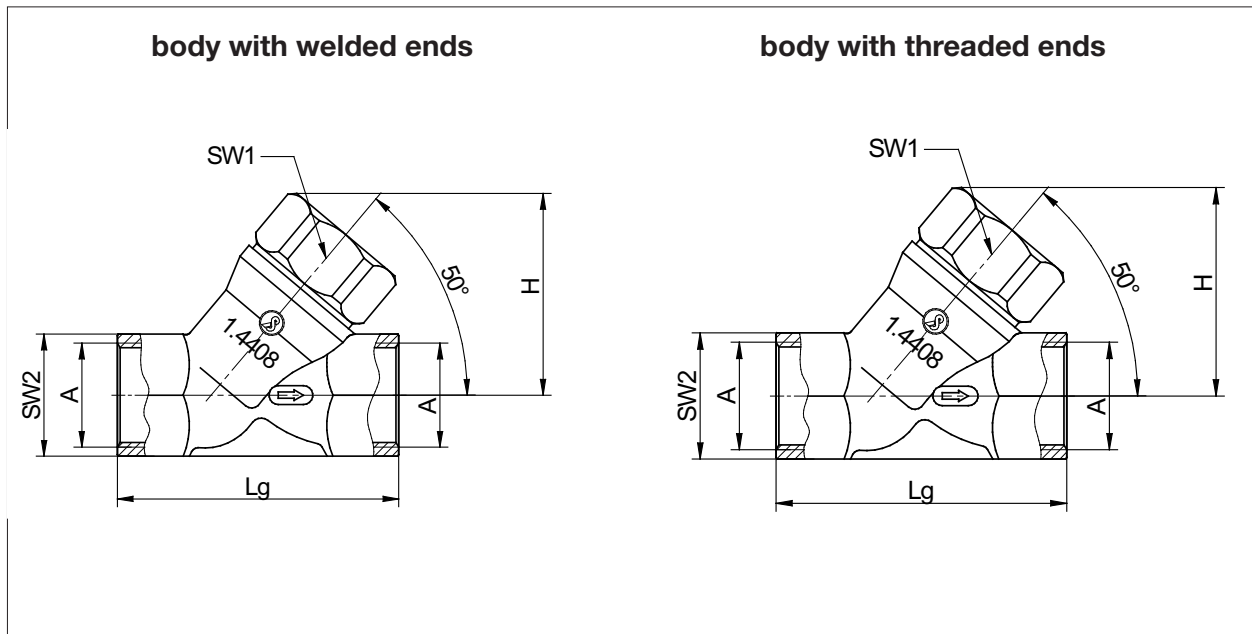

DN	A Rp	H	D	S	Lg	LS	SW1	SW2	Kvs value	Weight kg	Ordering number
10	3/8"	43,5	-	-	60	-	27	23	1,0	0,25	4059563
15	1/2"	42,5	21,3	2	65	80	27	25	2,6	0,25	4051500
20	3/4"	49	26,9	2,3	75	90	32	31	6	0,42	4051501
25	1"	57,5	33,7	2,6	90	100	36	39	11,5	0,65	4051502
32	1 1/4"	65	42,6	2,6	110	110	36	48	18,5	1,1	4051503
40	1 1/2"	74	48,3	2,6	120	120	27	55	28	1,05	4051504
50	2"	95	60,3	2,9	150	150	36	68	41	2,2	4051505
65	2 1/2"	137,5	76,1	2,9	180	180	36	85	75	4	4051506

Dimensions in mm

rectangular body

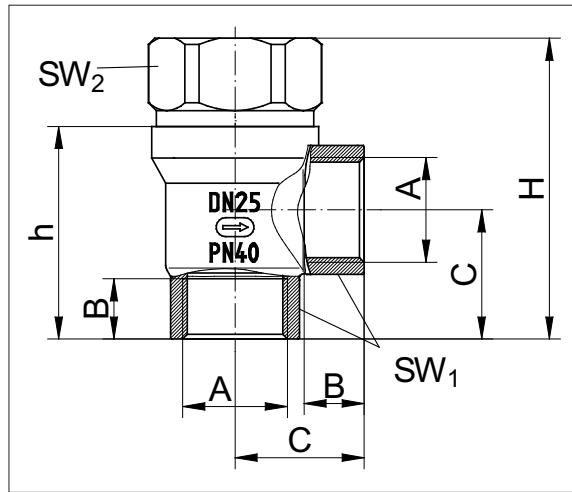

DN	with G-thread		with NPT-thread		C	SW1	SW2	h	H	Weight kg
	A	B	A	B						
15	G 1/2"	15	NPT 1/2"	14,5	41	25	32	64	75	1,3
20	G 3/4"	16,3	NPT 3/4"	15	41	32	36	66	88,5	1,7
25	G 1"	19,1	NPT 1"	17,9	41	41	36	67,5	95,5	2,0
32	G 1 1/4"	21,4	NPT 1 1/4"	18,4	65	50	27	93	125,5	2,2
40	G 1 1/2"	21,4	NPT 1 1/2"	18,4	65	55	36	101	140	3,4
50	G 2"	25,7	NPT 2"	18,4	65	68	36	116	166,5	5,3

Dimensions in mm

flanged body

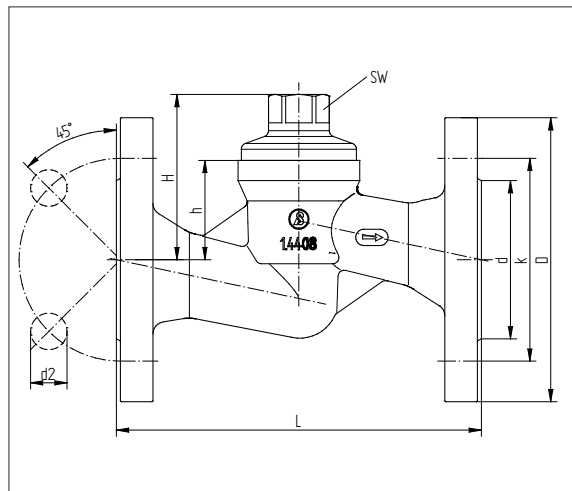

DN	L	D	k	H	h	d	d1	SW	Weight kg
15	130	95	65	43,7	33	45	14	32	3,78
20	150	105	75	61	38,5	58	14	36	3,84
25	160	115	85	72	44	68	14	36	4,40
32	180	140	100	81,5	49	78	18	27	6,05
40	200	150	110	98,5	59,5	88	18	36	8,11
50	230	165	125	131,4	81,2	102	18	36	11,55

Dimensions in mm

Text and pictures are not binding. We reserve the right, to alter the equipment.