

Safety Valves, angle type, bronze, type tested TÜV-SV.749. D/G

Standard safety valve

with soft valve seal, open bonnet, with lifting device

In- and outlet: female thread type G (BSPP) acc. to ISO 228/1

Part No. 06380.X.0000

with FPM valve seal for air and similar gases

Working temperature: -10°C / +14°F (263K) up to +185°C / +365°F (458K)

Part No. 06380.X.0300

with PTFE valve seal for air and similar gases

and saturated steam from 2.0 up to 10.0 bar.

Working temperature: -10°C / +14°F (263K) up to +185°C / +365°F (458K)

Part No. 06380.X.0600

with EPDM valve seal for air and similar gases

and saturated steam from 0.2 up to 8 bar. (saturated steam only to 3.5 bar)

Working temperature: -10°C / +14°F (263K) up to +150°C / +302°F (423K)

Available options - on request only:

· stainless steel spring - material 1.4571, external parts nickel plated

Applications:

Provided as safety device for protection against excessive pressure in pressure vessels.



Materials	DIN EN	ASTM
1 Body	CC491K	B 62 UNS C83600
2 Valve seal	FPM, PTFE or EPDM	
3 Disc	CW614N	B 283 UNS C38500
4 Stem	CW614N	B 283 UNS C38500
5 Bonnet	CW614N	B 283 UNS C38500
6 Spring	1.1200	A 576 Grade 1045
7 Lifting device	CW614N	B 283 UNS C38500
8 Closing cap	CW507L	B 30 UNS C26800

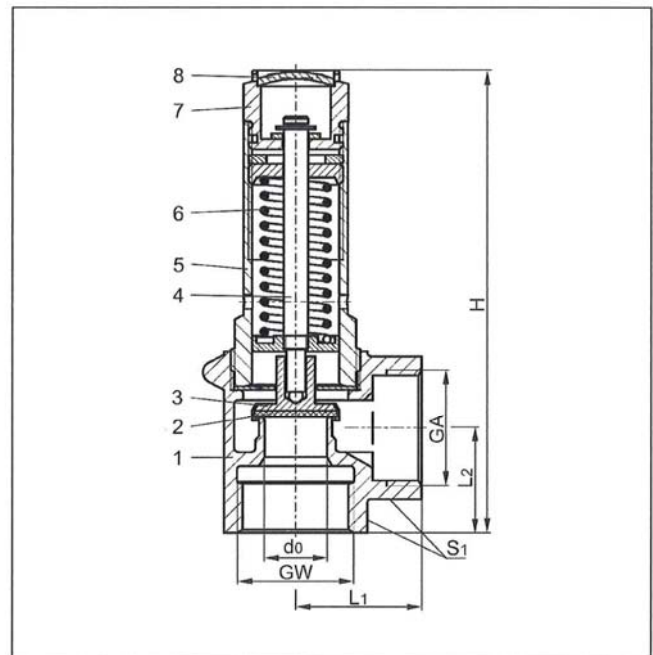

Essential: Valves are delivered at a set pressure, therefore when ordering please confirm set pressure, medium and temperature.

Standard marking acc. to Pressure Equipment Directive 97/23/EG (PED).



Type 06380	Technical data						
Nominal size	GW	1/2	3/4	1	1-1/4	1-1/2	2
Orifice	d ₀	12	15	18	20	24	28
Dimension code	.X.	0400	0600	1000	1200	1400	2000
Set pressure range FPM seal	bar	0.2-20	0.2-20	0.2-20	0.2-20	0.2-16	0.2-16
Set pressure range PTFE seal	bar	0.2-20	0.5-20	0.2-20	0.4-20	0.2-16	1.0-16
Set pressure range EPDM seal	bar	0.2-8	0.2-8	0.2-9	0.2-9	0.2-8	0.2-8
Outlet	GA	1/2	3/4	1	1-1/4	1-1/2	2
Height	H	99.0	112.5	132.5	152.8	175.5	200.4
Length	L ₁	25	30	36	40	48	56
Length	L ₂	22	25	30	35	40	48
Wrench size across flats	S ₁	27	32	41	50	58	70
Weight	ca. kg	0.24	0.40	0.70	1.07	1.65	2.65
Coeff. of discharge from 3.0 bar	α _w	0.47	0.37	0.52	0.57	0.52	0.50

Dimensions in mm.

Department eDocumentation

Phone. +49 7125 9497-41, -42, -53, -260, -330

Fax. +49 7125 9497-99

 e-mail: eDocumentation@riegler.de

edition 10/2013 Subject technical changes.

RIEGLER & Co. KG
www.riegler.net

Discharge capacities

Calculation of mass flow acc. to AD2000-Merkblatt A2

Medium:

Air in m³/h at 0°C and 1013.25 mbar

Saturated steam in kg/h

The capacity indicated below is for a fully opened valve.

d_0 - orifice

A_0 - flow area

Set pressure in bar (ü)	GW	1/2	3/4	1	1-1/4	1-1/2	2	1/2	3/4	1	1-1/4	1-1/2	2
	d_0 (mm) A_0 (mm ²) Medium	12.0 113.1	15.0 176.7	18.0 254.5	20.0 314.2	24.0 452.4	28.0 615.8	12.0 113.1	15.0 176.7	18.0 254.5	20.0 314.2	24.0 452.2	28.0 615.8
		Air						Saturated steam					
0.2		28	40	69	96	122	158	27	38	66	91	116	151
0.4		43	58	106	146	188	250	35	48	85	115	151	201
0.5		47	62	116	157	207	275	38	53	95	129	170	226
1.0		68	89	172	231	306	408	54	67	137	183	243	323
2.0		114	139	284	392	505	660	89	105	222	307	323	517
3.0		156	192	389	526	691	904	121	141	302	409	537	703
4.0		196	241	488	660	867	1135	151	176	376	509	669	875
5.0		236	290	587	794	1043	1366	181	210	450	609	801	1048
6.0		276	339	686	929	1220	1596	211	246	525	711	934	1222
7.0		315	388	785	1063	1396	1827	241	280	600	812	1067	1397
8.0		355	437	884	1197	1572	2058	270	314	672	910	1195	1564
9.0		395	486	984	1331	1748	2288	300	349	746	1009	1326	1735
10.0		435	535	1083	1465	1925	2519	329	382	821	1109	1457	1907
12.0		515	633	1281	1733	2277	2980	-	-	-	-	-	-
14.0		594	731	1479	2002	2629	3441	-	-	-	-	-	-
16.0		674	829	1677	2270	2982	3903	-	-	-	-	-	-
18.0		753	927	1876	-	-	-	-	-	-	-	-	-
20.0		833	1025	2074	-	-	-	-	-	-	-	-	-